

THE OPTIMIST CLASSES IIT-JAM TOPPERS



MANOJ KUMAR SINGH



ABHAY



PAWAN



SATYAM



SOUMIL GIRISH SAHU



BHOOMIJA



AKSHIT AGGARWAL



SHIKHAR CHAMOLI



RAVI SINGH ADHIKARI



GAURAV JHA



SWAPNIL JOSHI



LOKESH BHATT



GOPESH VISHVAKARMA



VAIBHAV



SHASWAT CHAMOLI

CSIR-NET-JRF RESULTS 2022



ANNU
DL01000308



ALANKAR
UP15000162



SAHIL RANA
HR09000108



JAYESTHI
RJ11000161



DASRATH
RJ06000682



VIVEK
UK01000439



UZAIR AHMED
UP02000246



SURYA PRATAP SINGH
RJ06000232



HIMANSHU
UP10000095



CHANDAN
RJ09000159



SAIKHOM JOHNSON
MN01000196



AJAY SAINI
RJ06001744



VIKAS YADAV
RJ06001102

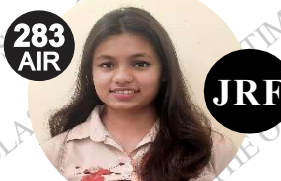

JYOTSNA KOHLI
UK02000262



SHYAM SUNDAR
RJ06000615

233, FIRST FLOOR, LAXMI NAGAR DELHI-110092

CALL@ 09871044043 www.theoptimistclasses.com Email: info@theoptimistclasses.com

THE OPTIMIST CLASSES

AN INSTITUTE FOR NET-JRF/GATE/IIT-JAM/JEST/TIFR/M.Sc ENTRANCE EXAMS

CONTACT: 9871044043

IIT - JAM PHYSICS

PREVIOUS YEAR QUESTION 2008

- The product PQ of any two real, symmetric matrices P and Q is:
 - symmetric of all P and Q
 - never symmetric
 - symmetric if $PQ = QP$
 - antisymmetric for all P and Q
- The work done by a force in moving particle of mass ' m ' from any point (z, y) to a neighbouring point $(x + dx, y + dy)$ is given by $dW = 2xydx + x^2 dy$. The work done for a complete cycle around a unit circle is:
 - 0
 - 1
 - 3
 - 2π
- $EFGH$ is a thin square plate of uniform density σ and side $4a$. Four point masses, each of mass m , are placed on the plate as shown in the figure. In the moment of inertia matrix ' I ' of the composite system,

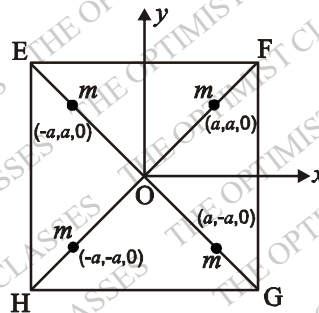

- Only I_{xy} is zero
 - Only I_{xz} and I_{yz} are zero.
 - All the product of inertia terms are zero
 - None
- The chemical potential of an ideal Bose gas at any temperature is :
 - Necessarily negative
 - Either zero or negative
 - Necessarily positive
 - Either zero or positive.
 - If the electrostatic potential at a point (x, y) is given by $V = (2x + 4y)$ volts, the electrostatic energy density at that point (in J/m^3) is :
 - $5\epsilon_0$
 - $10\epsilon_0$
 - $20\epsilon_0$
 - $\frac{1}{2}\epsilon_0(2x + 4y)^2$
 - In an inertial frame S , a stationary rod makes an angle θ with the x -axis. Another inertial frame S' moves with a velocity ' v ' with respect to S along the common $x - x'$ axis. As observed from S' the angle made by the rod with the $x' -$ axis is θ' . Which of the following statements is correct?
 - $\theta' < \theta$
 - $\theta' > \theta$
 - $\theta' < \theta$ if v is negative and $\theta' > \theta$ if v is positive
 - $\theta' > \theta$ if v is negative and $\theta' < \theta$ if v is positive.

7. Consider a doped semiconductor having the electron and the hole mobilities μ_n and μ_p , respectively. Its intrinsic carrier density is n_i . The hole concentration p for which the conductivity is minimum at a given temperature is:

(a) $n_i \sqrt{\frac{\mu_n}{\mu_p}}$ (b) $n_i \sqrt{\frac{\mu_p}{\mu_n}}$ (c) $n_i \left(\frac{\mu_p}{\mu_n} \right)$ (d) $n_i \left(\frac{\mu_n}{\mu_p} \right)$

8. Two coherent plane waves of light of equal amplitude, and each of wavelength $20\pi \times 10^{-8}$ m, propagating at an angle of $\frac{\pi}{1080}$ radian with respect to each other, fall almost normally on a screen. The fringe-width (i mm) on the screen is :

(a) 0.108 (b) 0.216 (c) 1.080 (d) 2.160

9. A circular disc (in the horizontal xy -plane) is spinning about a vertical axis through its centre 'O' with a constant angular velocity $\vec{\omega}$. As viewed from the reference frame of the disc, a particle is observed to execute uniform motion, in the anticlockwise sense, centered at P. When the particle is at the point Q, which of the following figures correctly represents the directions of the Coriolis force \vec{F}_{cor} and the centrifugal force \vec{F}_{cfg} ?

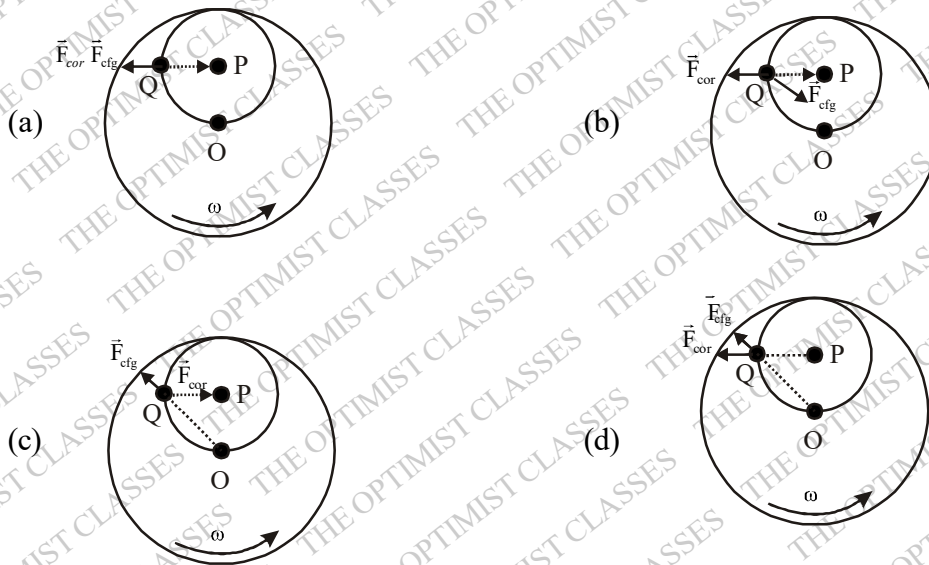

10. The instantaneous position $x(t)$ of a small block performing one-dimensional damped oscillation is $x(t) = Ae^{-\gamma t} \cos(\omega t + \alpha)$. Here, ω is the angular frequency, γ the damping coefficient, A the initial amplitude and α the initial phase. If $x|_{t=0} = 0$ and $\left. \frac{dx}{dt} \right|_{t=0} = v$, the values of A and α (with $n = 0, 1, 2, \dots$) are

(a) $A = \frac{v}{2\omega}, \alpha = \frac{(2n+1)\pi}{2}$ (b) $A = \frac{v}{\omega}, \alpha = n\pi$
 (c) $A = \frac{v}{\omega}, \alpha = \frac{(2n+1)\pi}{2}$ (d) $A = \frac{2v}{\omega}, \alpha = \frac{(2n+1)\pi}{2}$

11. A photon of wavelength ' λ ' is incident on a free electron at rest and is scattered in the backward direction. the fractional shift in its wavelength in terms of the Compton wavelength λ_c of the electron is :

(a) $\frac{\lambda_c}{2\lambda}$ (b) $\frac{2\lambda_c}{3\lambda}$ (c) $\frac{3\lambda_c}{2\lambda}$ (d) $\frac{2\lambda_c}{\lambda}$

12. The logic expression for the output Y of the following circuit is :

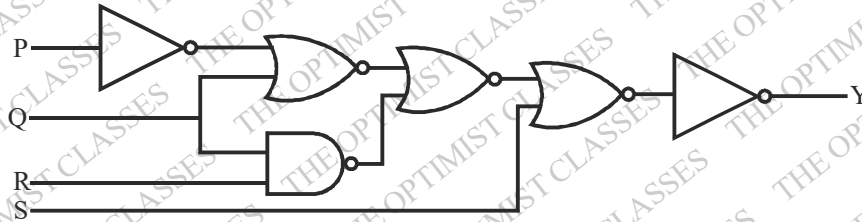

- (a) $\overline{\overline{P+Q+QR+S}}$ (b) $\overline{\overline{P+Q+QR+S}}$ (c) $\overline{\overline{P+Q+QR+S}}$ (d) $\overline{\overline{P+Q+QR+S}}$
13. The activity of a radioactive sample is decreased to 75% of the initial value after 30 days. The half-life (in days) of the sample is approximately [You may use $\ln 3 \approx 1.1$, $\ln 4 \approx 1.4$]
- (a) 38 (b) 45 (c) 59 (d) 69
14. The ratio of the second-neighbour distance to the nearest-neighbour distance to the nearest-neighbour distance in an fcc lattice is
- (a) $2\sqrt{2}$ (b) 2 (c) $\sqrt{3}$ (d) $\sqrt{2}$
15. A thermodynamic system is maintained at constant temperature and pressure. In thermodynamic equilibrium, its
- (a) Gibbs free energy is minimum (b) Enthalpy is maximum
(c) Helmholtz free energy is minimum (d) Internal energy is zero.
16. A thin hollow cylinder of radius and length both equal to L is closed at the bottom. A disc of radius $L/2$ is removed from the bottom as shown in figure. This object carries a uniform surface-charge density σ . Calculate the electrostatic potential at the point P on the axis of the cylinder as shown in the figure. [You may use

$$\int \frac{dx}{\sqrt{x^2 + a^2}} = \ln \left(x + \sqrt{x^2 + a^2} \right),$$

[21]

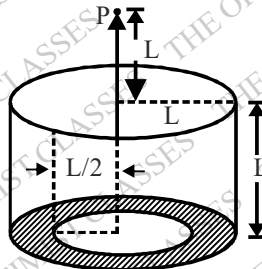

17. A particle of mass 1 kg is moving in a central field given by $\vec{F}_1(\vec{r}) = -\left(\frac{3}{r^2} + \frac{1}{r}\right)\hat{r}$
- (a) Assuming that the particle is moving in a circular orbit with angular momentum $2J$ -s, find the radius of the orbit. [12]
- (b) At $t=0$, an additional force $\vec{F}_2 = -\lambda\vec{v}$, where \vec{v} is the instantaneous velocity of the particle, is switched on. Shown that the magnitude of its angular momentum after a time $\frac{1}{\lambda}$ second is $\frac{2}{e}J$ -s [9]
18. An incompressible fluid enclosed between two horizontal surface located at $z=0$ and $z=d$. the fluid motion is two dimensional, and the velocity field $\vec{V}(x, z, t)$ is given by $\vec{V}(x, z, t) = u(x, z, t)\hat{x} + w(x, z, t)\hat{z}$ are periodic functions of the horizontal coordinate x with wavenumber k .

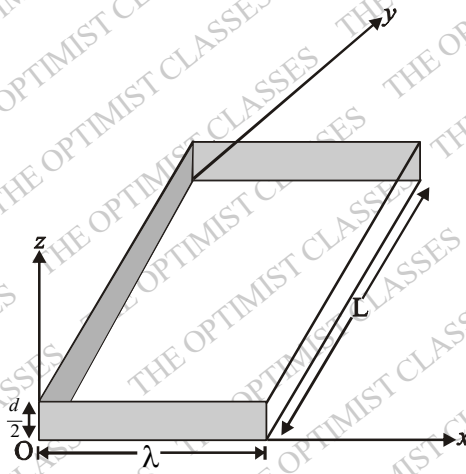

(a) If the vertical velocity $w(x, z, t) = A(t) \cos(kx) \sin\left(\frac{\pi z}{d}\right)$, find the horizontal velocity $u(x, z, t)$ using the equation of continuity. What is the vorticity field $\vec{\Omega} = \vec{\nabla} \times \vec{v}$?

(b) Find the net fluid flux from a parallelepiped of size $\lambda \times L \times \frac{d}{2}$ as shown in the figure, where $\lambda = \frac{2\pi}{k}$.

19. The wave function $\psi_n(x)$ of a particle confined to a one-dimensional box of length 'L' with rigid wall is given

$$\text{by } \psi_n(x) = \sqrt{\frac{2}{L}} \sin\left(\frac{n\pi x}{L}\right), \quad n = 1, 2, 3, \dots$$

(a) Determine the energy eigenvalues. Also, determine the eigenvalues and the eigenfunction of the momentum operator.

(b) Show the the energy eigenfunctions are not the eigenfunctions of the momentum operator.

20. A mass and spring system consists of two blocks of mass 'M' and one block of mass $m (< M)$. These blocks are connected with two identical springs of spring constant 'k' as shown in the figure. The system is constrained to move along a straight line on a frictionless horizontal surface. The spring follows Hooke's law. Find the angular frequencies of the independent oscillations (normal modes).



Now, the masses 'M' and 'm' are interchanged and the new arrangement is shown in the following figure:



The ratio of the frequency of the new arrangement to that of the old arrangement, when the middle block remains stationary, is $\sqrt{2}$. Find the ratio of the frequencies in the two arrangements when the middle block oscillates. [21]

21. A half-wave plate and a quarter-wave plate are placed between a polarizer P_1 and an analyzer P_2 . All of these are parallel to each other and perpendicular to the direction of propagation of unpolarized incident light (see figure). The optic-axis of the half wave plate makes an angle of 30° with respect to the pass-axis of P_1 and that of the quarter wave plate is parallel to the pass-axis of P_1 .

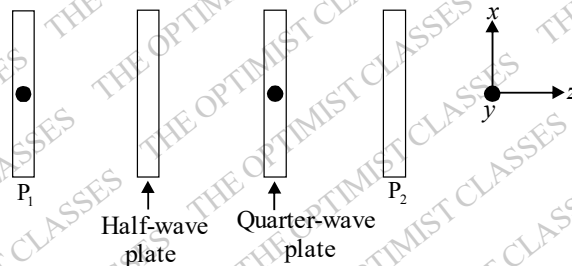

(a) Determine the state of polarization for the light after passing through

(i) the half wave plate and (ii) the quarter wave plate. [15]

(b) What should be the orientation of the pass-axis P_2 with respect to that of P_1 such that the intensity of the light emerging from P_2 is maximum? [6]

22. Consider a system N non-interacting distinguishable spin $-\frac{1}{2}$ particles, each of magnetic moment $\vec{\mu}$. The system is at an equilibrium temperature T in a magnetic field \vec{B} such that n particle have their magnetic moments aligned parallel to \vec{B} .

(a) Find the energy E and the entropy S of the system. [9]

(b) Using the relationship between E and S , find T . Hence determine the ratio n/N in terms of μ, B and T . [Use $\ln N! = N \ln N - N$] [12]

23. (a) An ideal gas, kept in contact with a heat reservoir, undergoes a quasistatic process in which its pressure gets doubled. Obtain the Maxwell relation from the differential form $dF = -SdT - PdV$ and evaluate the expression for the change in entropy of n moles of the gas. [9]

(b) Using $S = S(T, V)$, derive a general expression for $(\partial U / \partial V)_T$, where $U(S, V)$ is the internal energy. Evaluate it for the ideal gas as considered in part (a) Justify that the outcome is consistent with the expression for the average energy known from the kinetic theory. [12]

24. Consider an ideal Fermi gas consisting of N non-relativistic spin-1/2 particles confined to a length ' L ' in one dimension at $0 K$.

(a) Find an expression for the density of states and hence calculate the Fermi energy of the gas. [15]

(b) Find the mean energy per particle in terms of the Fermi energy. [6]

25. A square loop of side ' L ' and mass ' M ' is made of a wire of cross-sectional area A and resistance R . The loop, moving with a constant velocity $v_0 \hat{i}$ in the horizontal xy -plane, enters a region $0 \leq x \leq 2L$ having constant magnetic field $B \hat{k}$.

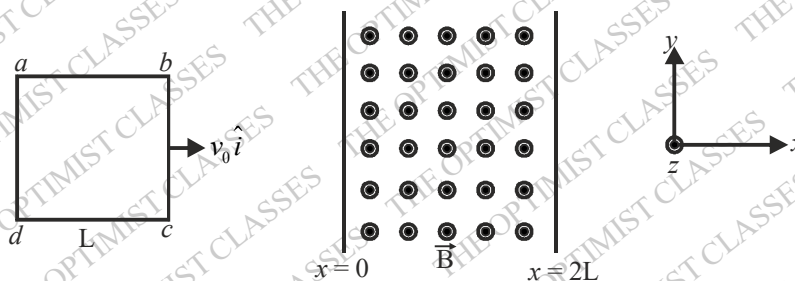

(a) Find an expression for the x-component of the force \vec{F} acting on the loop in terms of its velocity

$\vec{v}(t), B, L$ and R . [12]

(b) Find the speed of the loop as its side ad exits the field region at $x = 2L$ and sketch its variation with x . [9]

ANSWER KEY

- | | | | | | | | | | | | | | |
|-----|-----|-----|-----|-----|-----|-----|-----|-----|-----|-----|-----|-----|-----|
| 1. | (c) | 2. | (a) | 3. | (c) | 4. | (b) | 5. | (b) | 6. | (b) | 7. | (a) |
| 8. | (b) | 9. | (d) | 10. | (c) | 11. | (d) | 12. | (a) | 13. | (d) | 14. | (d) |
| 15. | (a) | 16. | (*) | 17. | (*) | 18. | (*) | 19. | (*) | 20. | (*) | 21. | (*) |
| 22. | (*) | 23. | (*) | 24. | (*) | 25. | (*) | | | | | | |