

# THE OPTIMIST CLASSES IIT-JAM TOPPERS



**MANOJ KUMAR SINGH**



**ABHAY**



**PAWAN**



**SATYAM**



**SOUMIL GIRISH SAHU**



**BHOOMIJA**



**AKSHIT AGGARWAL**



**SHIKHAR CHAMOLI**



**RAVI SINGH ADHIKARI**



**GAURAV JHA**



**SWAPNIL JOSHI**



**LOKESH BHATT**



**GOPESH VISHVAKARMA**



**VAIBHAV**



**SHASWAT CHAMOLI**

# CSIR-NET-JRF RESULTS 2022



**ANNU**  
DL01000308



**ALANKAR**  
UP15000162



**SAHIL RANA**  
HR09000108



**JAYESTHI**  
RJ11000161



**DASRATH**  
RJ06000682



**VIVEK**  
UK01000439



**UZAIR AHMED**  
UP02000246



**SURYA PRATAP SINGH**  
RJ06000232



**HIMANSHU**  
UP10000095



**CHANDAN**  
RJ09000159



**SAIKHOM JOHNSON**  
MN01000196



**AJAY SAINI**  
RJ06001744



**VIKAS YADAV**  
RJ06001102



**JYOTSNA KOHLI**  
UK02000262



**SHYAM SUNDAR**  
RJ06000615

# THE OPTIMIST CLASSES

AN INSTITUTE FOR NET-JRF/GATE/IIT-JAM/JEST/TIFR/M.Sc ENTRANCE EXAMS

CONTACT: 9871044043

## IIT - JAM PHYSICS

### PREVIOUS YEAR QUESTION 2013

1. The inverse of the matrix

$$M = \begin{pmatrix} 0 & 1 & 1 \\ 0 & 0 & 1 \\ 1 & 0 & 0 \end{pmatrix} \text{ is}$$

- (a)  $M^{-1}$                       (b)  $M^2 - I$                       (c)  $I - M^2$                       (d)  $I - M$   
where  $I$  is the identity matrix.

2. The value of  $\sqrt{i} + \sqrt{-i}$ , where  $i = \sqrt{-1}$ , is

- (a) 0                      (b)  $\frac{1}{\sqrt{2}}$                       (c)  $\sqrt{2}$                       (d)  $-\sqrt{2}$

3. A particle is released at  $x = 1$  in a force field  $\vec{F}(x) = \left(\frac{2}{x^2} - \frac{x^2}{2}\right)\hat{e}_x$ ,  $x \geq 0$ . Which one of the following statements is FALSE?

- (a)  $\vec{F}(x)$  is conservative.  
(b) The angular momentum of the particle about the origin is constant.  
(c) The particle moves towards  $x = \sqrt{2}$   
(d) The particle moves towards the origin.

4. A traveling pulse is given by  $f(x, t) = A \exp\left(\frac{2abxt - a^2x^2 - b^2t^2}{c^2}\right)$ , where  $A$ ,  $a$ ,  $b$  and  $c$  are positive constant of appropriate dimensions. The speed of pulse is

- (a)  $\frac{b}{a}$                       (b)  $\frac{2b}{a}$                       (c)  $\frac{cb}{a}$                       (d)  $\frac{b}{2a}$

5. If the dimensions of mass, length, time and charge are  $M$ ,  $L$ ,  $T$  and  $C$  respectively, the dimensions of the magnetic induction field  $\vec{B}$  is

- (a)  $ML^2T^{-1}C^{-1}$                       (b)  $MT^{-1}C^{-1}$                       (c)  $L^2T^{-1}C$                       (d)  $L^{-1}T^{-1}C$

6. A blackbody at temperature  $T$  emits radiation at a peak wavelength  $\lambda$ . If the temperature of the blackbody becomes  $4T$ , the new peak wavelength is

- (a)  $\frac{1}{256}\lambda$                       (b)  $\frac{1}{64}\lambda$                       (c)  $\frac{1}{16}\lambda$                       (d)  $\frac{1}{4}\lambda$

7. Let  $N_{MB}$ ,  $N_{FD}$  denote the number of ways in which two particles can be distributed in two energy states

**233, FIRST FLOOR, LAXMI NAGAR DELHI-110092**

CALL@ 09871044043 www.theoptimistclasses.com Email: info@theoptimistclasses.com

according to Maxwell-Boltzmann, Bose-Einstein and Fermi-Dirac statistics respectively. Then:

$$N_{MB} : N_{BE} : N_{FD} \text{ is:}$$

- (a) 4 : 3 : 1      (b) 4 : 2 : 3      (c) 4 : 3 : 3      (d) 4 : 3 : 2

8. Electric field component of an electromagnetic radiation varies with time as

$E = a(\cos \omega_0 t + \sin \omega t \cos \omega_0 t)$ , where  $a$  is a constant and the values of  $\omega$  and  $\omega_0$  are  $1 \times 10^{15} \text{ s}^{-1}$  and  $5 \times 10^{15} \text{ s}^{-1}$ , respectively. This radiation falls on a metal of work function  $2 \text{ eV}$ . The maximum kinetic energy (in eV) of photoelectrons is:

- (a) 0.64      (b) 1.30      (c) 1.70      (d) 1.95

9. The fraction of volume unoccupied in the unit cell of the body centered cubic lattice is

- (a)  $\frac{8 - \sqrt{3}\pi}{8}$       (b)  $\frac{\sqrt{3}\pi}{8}$       (c)  $\frac{6 - \sqrt{2}\pi}{6}$       (d)  $\frac{\pi}{3\sqrt{2}}$

10. For an ideal op-amp circuit given below, the dc gain and the cut off frequency, respectively are

- (a) 1 and 1 kHz      (b) 1 and 100 Hz      (c) 11 and 1 kHz      (d) 11 and 100 Hz

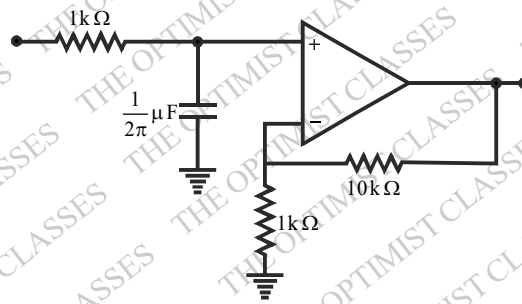

11. The solution of the differential equation  $dz(x, y) + xz(x, y)dx + yz(x, y)dy = 0$  is .....

12. Given that  $f(1) = 1$ ,  $f'(1) = 1$  and  $f''(1) = 1$ , the value of  $f\left(\frac{1}{2}\right)$  is .....

13. Two tubes A and B are connected through another tube C. A mercury manometer is connected between B and C (see figure). The diameter of B and C are  $0.04 \text{ m}$  and  $0.01 \text{ m}$ , respectively. An incompressible fluid of density  $1.0 \times 10^3 \text{ kg m}^{-3}$  enters A, and leaves B with a constant speed  $0.2 \text{ ms}^{-1}$ . If the density of mercury is  $13.6 \times 10^3 \text{ kg m}^{-3}$ , the height ' $h$ ' of the mercury column in the manometer is .....  
(The acceleration due to gravity  $g = 10 \text{ ms}^{-2}$ )

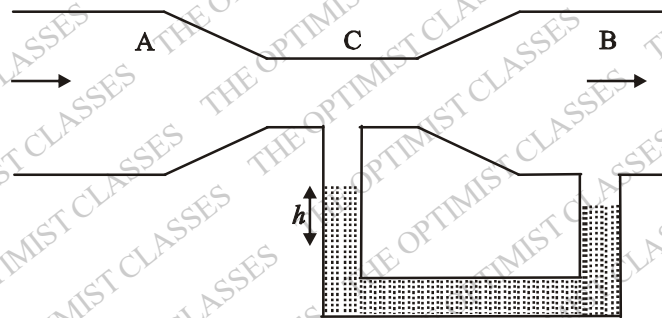

14. The path of a particle of mass ' $m$ ', moving under the influence of a central force, in plane polar coordinates is given by  $r = r_0 e^{k\theta}$ , where  $r_0$  and  $k$  are positive constants of appropriate dimensions. The angular momentum of the particle is  $L$  and its total energy is zero. The potential energy function  $V(r)$ , in terms of  $m$ ,  $L$  and  $k$  is .....

15. The dimensions of a thin convex lens of refractive index  $n$  are shown in the figure. The radius of curvature of the lens in terms of  $n$ ,  $h$  and  $\delta$  (where,  $\delta \ll h$ ) is .....

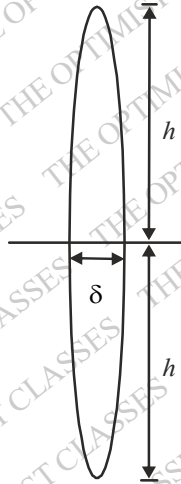

16. A charged particle of mass  $m$ , charge  $q$  and constant velocity  $\vec{v}$  enters a uniform magnetic field  $\vec{B} = B_0 \hat{e}_x$ , ( $B_0 > 0$ ), at an angle  $\theta$  to the direction of magnetic field. Find the angle  $\theta$ , if in one revolution of the helical motion, the particle advances along the direction of the magnetic field a distance equal to the radius of the helical path. ....
17. Two thermally isolated identical systems have heat capacities which vary as  $C_V = \beta T^3$  (where  $\beta > 0$ ). Initially one system is at 300K and the other at 400K. The systems are then brought into thermal contact and the combined system is allowed to reach thermal equilibrium. The final temperature of the combined system is .....
18. A beam of X-ray of wavelength 0.2 nm is incident on a free electron and gets scattered in a direction with respect to the direction of the incident radiation resulting in maximum wavelength shift. The percentage energy loss of the incident radiation is .....
19. A free particle of mass ' $m$ ' is confined to a region of length  $L$ . The de-Broglie wave associated with the particle is sinusoidal in nature as given in the figure. The energy of the particle is .....

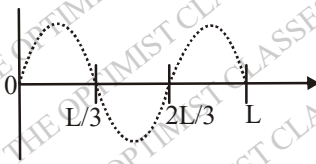

20. A variable power supply ( $5V - 20V$ ) is connected to a Zener diode specified by a breakdown voltage of 10 V (see figure). The ratio of the maximum power to the minimum power dissipated across the load resistor is .....

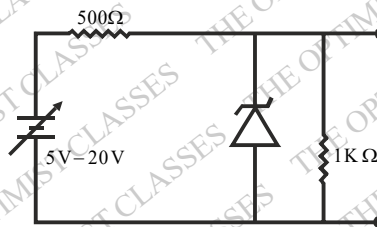

21. Apply Gauss divergence theorem to the gravitational field due to spherical object of mass  $M$  and uniform density  $\rho$  located at the origin. Obtain Gauss's law for gravitation (analogous to the Gauss law in electro-

statics) in integral and differential forms.

22. A thin annular disc of inner and outer radii  $a$  and  $b$  ( $a < b$ ) respectively has uniform mass density  $\sigma_s$  and is placed in the  $x$ - $y$ -plane such that its axis lies along the  $z$ -axis. Determine the gravitational force due to the disc on a particle of mass ' $m$ ' located on the  $z$ -axis at a distance  $z$  from the origin. If the particle is released at  $z$ , such that  $z \ll a, b$ , describe the nature of motion of the particle.

23. A concentric spherical volume of inner radius ' $a$ ' and outer radius ' $b$ ' is filled with a material of finite conductivity specified by  $\sigma(r) = \frac{A}{r^2}$

where  $A$  is a positive constant of appropriate dimensions. The outer surface is grounded and the inner surface is maintained at a potential  $V_0$ . Calculate the resistance of this configuration.

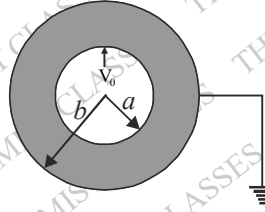

24. A conducting solid sphere of radius  $a$ , carrying a charge  $q$  is kept in a dielectric of dielectric constant  $k$ , such that half the sphere is surrounded by the dielectric as shown in figure. Find the surface charge densities in the upper and lower hemispherical surfaces.

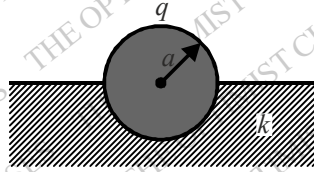

25. A particle of mass ' $m$ ' is subjected to a potential  $V(x) = ax^2$ ,  $-\infty < x < \infty$ , where ' $a$ ' is a positive constant of appropriate dimensions. Using the relation  $\Delta x \Delta p \approx \frac{\hbar}{2}$ , estimate the minimum energy of the particle.

26. A hollow cylinder (closed at both ends) with adiabatic walls is divided into ' $n$ ' equal cells ( $C_1, C_2, \dots, C_n$ ) using discs  $D_1, D_2, \dots, D_{n-1}$  (see figure). The discs can slide freely without friction. The first disc ( $D_1$ ) is adiabatic and the remaining discs are diathermal (thermally conducting). Each cell contains one mole of ideal monoatomic gas. Let the initial pressure, volume and temperature of each cell be  $P_0, V_0$  and  $T_0$ , respectively. The gas in cell  $C_1$  (first cell) is heated slowly until the temperature of the gas in cell  $C_n$  (last cell) reaches final equilibrium temperature  $4T_0$ . Find the volume of the first cell in terms of the number of cells ( $n$ ) and the initial volume ( $V_0$ ).

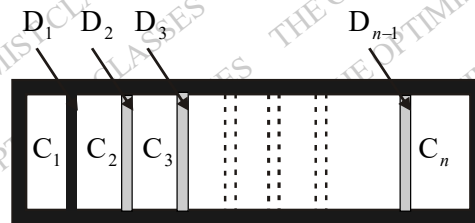

27. A spaceship  $S_1$  leaves the Earth along the positive  $x$ -direction. Another spaceship  $S_2$  also leaves the Earth

along the direction which makes an angle  $60^\circ$  with x-axis. The speeds of  $S_1$  and  $S_2$  are measured as  $0.6c$  and  $0.9c$  respectively by an observer on the Earth. Find the speed of  $S_2$  as measured by an observer in  $S_1$ .

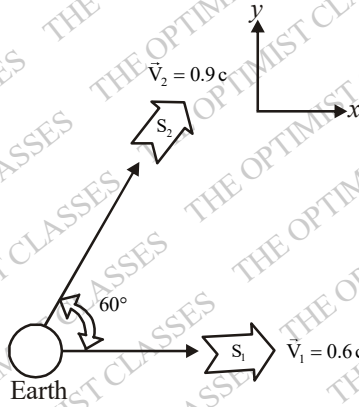

28. For the given circuit, calculate the input impedance, output impedance and voltage gain.

Use  $\beta = 200$ ,  $V_{BE} = 0.7 \text{ V}$  and  $r_e = \frac{26 \text{ mV}}{I_E}$

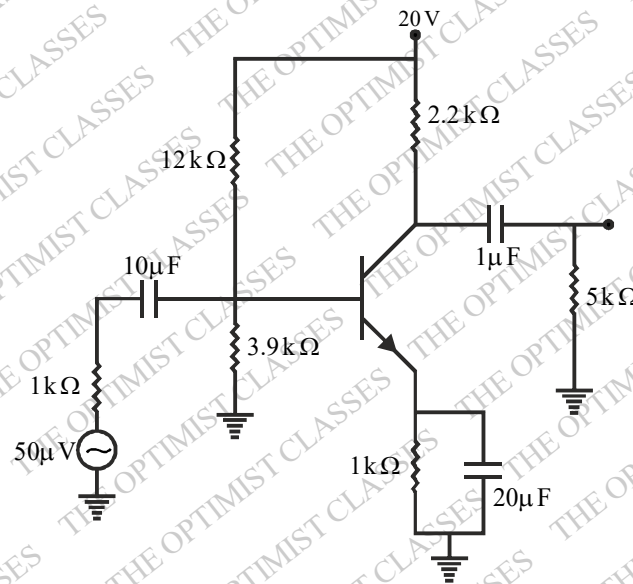

29. The mass density of a disc of mass ' $m$ ' and radius  $R$  varies as

$$\rho(r) = \rho_0 \left(1 - \frac{r}{R}\right) \text{ for } 0 \leq r \leq R$$

$$= 0 \text{ for } r > R$$

Find the moment of inertia of the disc about the axis perpendicular to the plane of the disc and passing through the centre of the disc in terms of  $m$  and  $R$ .

30. The speed of sound propagation in air as a function of temperature  $T$  is given by  $v = \alpha T$ , where  $\alpha$  is a constant of appropriate dimensions. Calculate the time taken for a sound wave to travel a distance  $L$  between two points A and B, if the air temperature between the points varies linearly from  $T_1$  to  $T_2$ .

## ANSWER KEY

- |     |     |     |     |     |     |     |     |     |     |     |     |     |     |
|-----|-----|-----|-----|-----|-----|-----|-----|-----|-----|-----|-----|-----|-----|
| 1.  | (b) | 2.  | (c) | 3.  | (d) | 4.  | (a) | 5.  | (b) | 6.  | (d) | 7.  | (a) |
| 8.  | (d) | 9.  | (a) | 10. | (c) | 11. | (*) | 12. | (*) | 13. | (*) | 14. | (*) |
| 15. | (*) | 16. | (*) | 17. | (*) | 18. | (*) | 19. | (*) | 20. | (*) | 21. | (*) |
| 22. | (*) | 23. | (*) | 24. | (*) | 25. | (*) | 26. | (*) | 27. | (*) | 28. | (*) |
| 29. | (*) | 30. | (*) |     |     |     |     |     |     |     |     |     |     |