

# THE OPTIMIST CLASSES

## IIT-JAM TOPPERS



**8**  
AIR  
**MANOJ KUMAR SINGH**



**9**  
AIR  
**ABHAY**



**12**  
AIR  
**PAWAN**



**15**  
AIR  
**SATYAM**



**21**  
AIR  
**SOUMIL GIRISH SAHU**



**29**  
AIR  
**BHOOMIJA**



**31**  
AIR  
**AKSHIT AGGARWAL**



**32**  
AIR  
**SHIKHAR CHAMOLI**



**33**  
AIR  
**RAVI SINGH ADHIKARI**



**44**  
AIR  
**GAURAV JHA**



**56**  
AIR  
**SWAPNIL JOSHI**



**65**  
AIR  
**LOKESH BHATT**



**75**  
AIR  
**GOPESH VISHVAKARMA**



**77**  
AIR  
**VAIBHAV**



**80**  
AIR  
**SHASWAT CHAMOLI**

# CSIR-NET-JRF RESULTS 2022



**ANNU**  
DL01000308

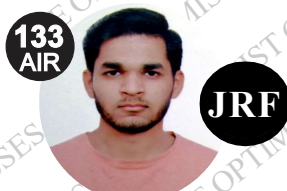

**ALANKAR**  
UP15000162



**SAHIL RANA**  
HR09000108



**JAYESTHI**  
RJ11000161



**DASRATH**  
RJ06000682



**VIVEK**  
UK01000439



**UZAIR AHMED**  
UP02000246



**SURYA PRATAP SINGH**  
RJ06000232



**HIMANSHU**  
UP10000095



**CHANDAN**  
RJ09000159



**SAIKHOM JOHNSON**  
MN01000196



**AJAY SAINI**  
RJ06001744



**VIKAS YADAV**  
RJ06001102



**JYOTSNA KOHLI**  
UK02000262



**SHYAM SUNDAR**  
RJ06000615

# THE OPTIMIST CLASSES

AN INSTITUTE FOR NET-JRF/GATE/IIT-JAM/JEST/TIFR/M.Sc ENTRANCE EXAMS

CONTACT: 9871044043

## GATE PAPER 2004

Q.1 - Q. 30 : Carry ONE mark each.

Q1. For the function  $\phi = x^2y + xy$  the value of  $|\vec{\nabla}\phi|$  at  $x = y = 1$  is

- (a) 5 (b)  $\sqrt{5}$  (c) 13 (d)  $\sqrt{13}$

Q2. The average of the function in the interval is

- (a)  $1/2$  (b)  $2/\pi$  (c)  $1/\pi$  (d)  $4/\pi$

Q3. Identify the points of unstable equilibrium for the potential shown in the figure.

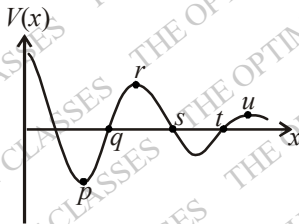

- (a) p and s (b) q and t (c) r and u (d) r and s

Q4. Which one of the following remains invariant under Lorentz transformations?

(a)  $\frac{\partial}{\partial x} + \frac{\partial}{\partial y} + \frac{\partial}{\partial z} - \frac{1}{c^2} \frac{\partial}{\partial t}$  (b)  $\frac{\partial^2}{\partial x^2} + \frac{\partial^2}{\partial y^2} + \frac{\partial^2}{\partial z^2} + \frac{1}{c^2} \frac{\partial^2}{\partial t^2}$

(c)  $\frac{\partial^2}{\partial x^2} + \frac{\partial^2}{\partial y^2} + \frac{\partial^2}{\partial z^2} - \frac{1}{c^2} \frac{\partial^2}{\partial t^2}$  (d)  $\frac{\partial^2}{\partial x^2} + \frac{\partial^2}{\partial y^2} + \frac{\partial^2}{\partial z^2}$

Q5. A charge  $+q$  is kept at a distance of  $2R$  from the centre of a grounded conducting sphere of radius  $R$ . The image charge and its distance from the centre are, respectively

- (a)  $-\frac{q}{2}$  and  $\frac{R}{2}$  (b)  $-\frac{q}{2}$  and  $\frac{R}{4}$  (c)  $-q$  and  $\frac{R}{2}$  (d)  $+\frac{q}{2}$  and  $\frac{R}{2}$

Q6. The state of polarization of light with the electric field vector  $\vec{E} = \hat{i}E_0 \cos(kz - \omega t) - \hat{j}E_0 \cos(kz - \omega t)$  is :

- (a) Linearly polarized along z-direction  
(b) Linearly polarized at  $-45^\circ$  to x-axis  
(c) Circularly polarized  
(d) Elliptically polarized with the major axis along x-axis

Q7. The resonance widths  $\Gamma$  of  $\rho$ ,  $\omega$  and  $\phi$  particle resonances satisfy the relation  $\Gamma_\rho > \Gamma_\omega > \Gamma_\phi$ . Their life-

times satisfy the relation

- (a)  $\tau_\rho > \tau_\omega > \tau_\phi$       (b)  $\tau_\rho < \tau_\omega < \tau_\phi$       (c)  $\tau_\rho = \tau_\omega = \tau_\phi$       (d)  $\tau_\rho > \tau_\omega < \tau_\phi$

- Q8. The time independent Schrödinger equation of a system represents the conservation of the  
 (a) total binding energy of the system.      (b) total potential energy of the system.  
 (c) total kinetic energy of the system.      (d) total energy of the system.
- Q9. In a hydrogen atom, the accidental or Coulomb degeneracy for the  $n = 4$  state is  
 (a) 4      (b) 16      (c) 18      (d) 32
- Q10. The Hamiltonian of a particle is given by  $H = \frac{p^2}{2m} + V(|\vec{r}|) + \phi(|\vec{r}|) \vec{L} \cdot \vec{S}$  where  $\vec{S}$  is the spin,  $V(|\vec{r}|)$  and  $\phi(|\vec{r}|)$  are Potential functions and  $\vec{L} = \vec{r} \times \vec{p}$  is the angular momentum. The Hamiltonian does NOT commute with  
 (a)  $\vec{L} + \vec{S}$       (b)  $\vec{S}^2$       (c)  $L_z$       (d)  $\vec{L}^2$
- Q11. The spectral terms for a certain electronic configuration are given by  ${}^3D, {}^1D, {}^3P, {}^1P, {}^5S, {}^3S$ . The term with the lowest energy is:  
 (a)  ${}^5S$       (b)  ${}^3P$       (c)  ${}^3D$       (d)  ${}^3S$
- Q12. The degeneracy of the spectral term  ${}^3F$  is:  
 (a) 7      (b) 9      (c) 15      (d) 21
- Q13. The Lande g factor the level  ${}^3D_3$  is:  
 (a)  $\frac{2}{3}$       (b)  $\frac{3}{2}$       (c)  $\frac{3}{4}$       (d)  $\frac{4}{3}$
- Q14. All vibrations producing a change in the electric dipole moment of a molecule yield  
 (a) Raman spectra      (b) Infrared spectra      (c) Ultra-violet spectra      (d) X-ray spectra
- Q15. For any process, the second law of thermodynamics requires that the change of entropy of the universe be  
 (a) positive only      (b) positive or zero      (c) zero only      (d) negative or zero
- Q16. The dimension of phase space of ten rigid diatomic molecules is  
 (a) 5      (b) 10      (c) 50      (d) 100
- Q17. The specific heat of an ideal Fermi gas in 3-dimension at very low temperature (T) varies as  
 (a) T      (b)  $T^{3/2}$       (c)  $T^2$       (d)  $T^3$
- Q18. Which one of the following is a first order phase transition?  
 (a) Vaporization of a liquid at its boiling point      (b) Ferromagnetic to paramagnetic  
 (c) Normal liquid He to superfluid He      (d) Superconducting to normal state
- Q19. The  $c/a$  ratio for an ideal hexagonal closed packed structure is  
 (a)  $2/\sqrt{3}$       (b)  $\sqrt{8}$       (c)  $\sqrt{5}$       (d)  $\sqrt{8/3}$
- Q20. The number of independent elastic constants in an isotropic cubic solid is  
 (a) 1      (b) 2      (c) 3      (d) 4
- Q21. The effective mass of an electron in a semiconductor  
 (a) can never be positive      (b) can never be negative  
 (c) can be positive or negative      (d) depends on its spin
- Q22. The critical magnetic field for a solid in superconducting state  
 (a) does not depend upon temperature      (b) increase if the temperature increases  
 (c) increases if the temperature decreases      (d) does not depend on the transition temperature

- Q23. The volume of a nucleus in an atom is proportional to the  
 (a) mass number (b) Proton Number  
 (c) neutron number (d) electron number
- Q24. As one moves along the of stability from  $^{56}\text{Fe}$  to  $^{235}\text{U}$  nucleus, the nuclear binding energy per particle decreases from about 8.8 MeV to 7.6 MeV. This trend is mainly due to the  
 (a) short range nature of the nuclear force (b) long range nature of the Coulomb forces  
 (c) tensor nature of the nuclear forces (d) spin dependence of the nuclear forces
- Q25. A thermal neutron having speed  $v$  impinges on a  $\text{U}^{235}$  nucleus. The reaction cross-section is proportional to  
 (a)  $v^{-1}$  (b)  $v$  (c)  $v^{1/2}$  (d)  $v^{-1/2}$
- Q26. Choose the particle with zero Baryon number from the list given below  
 (a) pion (b) neutron (c) proton (d)  $\Delta^+$
- Q27. A bipolar junction transistor with one junction forward biased and either the collector or emitter open, operates in the  
 (a) cut-off region (b) saturation region (c) pinch-off region (d) active region
- Q28. A field effect transistor is a  
 (a) Unipolar device (b) Special type of bipolar junction transistor.  
 (c) Unijunction device (d) device with low input impedance
- Q29. The inverting input terminal of an operational amplifier (op-amp) is shorted with the output terminal apart from being grounded. A voltage signal  $v_i$  is applied to the non-inverting input terminal of the op-amp. Under this configuration, the op-amp functions as  
 (a) an open loop inverter (b) a voltage to current converter  
 (c) a voltage follower (d) an oscillator
- Q30. A half-adder is a digital circuit with  
 (a) Three inputs and one output (b) Three inputs and two outputs  
 (c) Two inputs and one output (d) Two input and two outputs.

**Q. 31 - Q.90: Carry Two marks each.**

- Q31. A real traceless  $4 \times 4$  unitary matrix has two eigenvalues -1 and +1. The other eigenvalues are:  
 (a) zero and +2 (b) zero and +1 (c) zero and -2 (d) -1 and +1

- Q32. The eigenvalues of the matrix  $\begin{pmatrix} 1 & i \\ -i & 1 \end{pmatrix}$  are:  
 (a) +1 and +1 (b) zero and +1 (c) zero and +2 (d) -1 and +1

- Q33. The inverse of the complex number  $\frac{3+4i}{3-4i}$  is  
 (a)  $\frac{7}{25} + i\frac{24}{25}$  (b)  $-\frac{7}{25} + i\frac{24}{25}$  (c)  $\frac{7}{25} - i\frac{24}{25}$  (d)  $-\frac{7}{25} - i\frac{24}{25}$

- Q34. The value of  $\int_C \frac{dz}{(z^2+a^2)}$ , where  $C$  is a unit circle (anti clockwise) centered at the origin in the complex  $z$ -plane is:  
 (a)  $\pi$  for  $a=2$  (b) zero for  $a=\frac{1}{2}$  (c)  $4\pi$  for  $a=2$  (d)  $\frac{\pi}{2}$  for  $a=\frac{1}{2}$

Q35. The Laplace transform of  $f(t) = \sin \pi t$  is  $F(s) = \frac{\pi}{(s^2 + \pi^2)}$ ,  $s > 0$ . Therefore, the Laplace transform of

$t \sin \pi t$  is:

- (a)  $\frac{\pi}{s^2(s^2 + \pi^2)}$  (b)  $\frac{2\pi}{s^2(s^2 + \pi^2)^2}$  (c)  $\frac{2\pi s}{(s^2 + \pi^2)^2}$  (d)  $\frac{2\pi s}{(s^2 + \pi^2)^2}$

Q36. A periodic function  $f(x) = x$  for  $-\pi < x < \pi$  has the Fourier series representation

$$f(x) = \sum_{n=1}^{\infty} \left(-\frac{2}{n}\right) (-1)^n \sin nx. \text{ Using this, one finds the sum } \sum_{n=1}^{\infty} \frac{1}{n^2} \text{ to be}$$

- (a)  $2 \ln 2$  (b)  $\frac{\pi^2}{3}$  (c)  $\frac{\pi^2}{6}$  (d)  $\pi \ln 2$

Q37. The Fourier transform  $F(k)$  of a function  $f(x)$  is defined as  $F(k) = \int_{-\infty}^{\infty} dx f(x) \exp(ikx)$ . The  $F(k)$  for  $f(x)$

$$= \exp(-x^2) \text{ is: [Given: } \int_{-\infty}^{\infty} \exp(-x^2) dx = \sqrt{\pi} \text{]}$$

- (a)  $\pi \exp(-k)$  (b)  $\sqrt{\pi} \exp\left(\frac{-k^2}{4}\right)$  (c)  $\frac{\sqrt{\pi}}{2} \exp\left(\frac{-k^2}{2}\right)$  (d)  $\sqrt{2\pi} \exp(-k^2)$

Q38. The Lagrangian of a particle moving in a plane under the influence of a central potential is given by

$$L = \frac{1}{2} m (\dot{r}^2 + r^2 \dot{\theta}^2) - V(r)$$

The generalized momenta corresponding to  $r$  and  $\theta$  are given by

- (a)  $m\dot{r}$  and  $mr^2\dot{\theta}$  (b)  $m\dot{r}$  and  $mr\dot{\theta}$  (c)  $m\dot{r}^2$  and  $mr^2\dot{\theta}$  (d)  $m\dot{r}^2$  and  $mr^2\dot{\theta}^2$

Q39. A particle of mass  $m$  is attached to a thin uniform rod of length  $a$  and mass  $4m$ . The distance of the particle from the center of mass of the rod is  $a/4$ . The moment of inertia of the combination about an axis passing through O normal to the rod is



- (a)  $\frac{64}{48} ma^2$  (b)  $\frac{91}{48} ma^2$  (c)  $\frac{27}{48} ma^2$  (d)  $\frac{51}{48} ma^2$

Q40. A rigid frictionless rod rotates anticlockwise in a vertical plane with angular velocity  $\vec{\omega}$ . A bead of mass  $m$  moves outward along the rod with constant velocity  $\vec{u}_0$ . The bead will experience a coriolis force

- (a)  $2mu_0\omega\hat{\theta}$  (b)  $-2mu_0\omega\hat{\theta}$  (c)  $4mu_0\omega\hat{\theta}$  (d)  $-mu_0\omega\hat{\theta}$

Q41. The Hamiltonian corresponding to the Lagrangian  $L = ax^2 + by^2 - kxy$  is

- (a)  $\frac{p_x^2}{2a} + \frac{p_y^2}{2b} + kxy$  (b)  $\frac{p_x^2}{4a} + \frac{p_y^2}{4b} - kxy$  (c)  $\frac{p_x^2}{4a} + \frac{p_y^2}{4b} + kxy$  (d)  $\frac{p_x^2 + p_y^2}{4ab} + kxy$

Q42. The value of the Poisson bracket  $[\vec{a} \cdot \vec{r}, \vec{b} \cdot \vec{p}]$ , where  $\vec{a}$  and  $\vec{b}$  are constant vectors, is

- (a)  $\vec{a}\vec{b}$  (b)  $\vec{a} - \vec{b}$  (c)  $\vec{a} + \vec{b}$  (d)  $\vec{a} \cdot \vec{b}$

Q43. A mass  $m$  is connected on either side with a spring each of spring constant  $k_1$  and  $k_2$ . The free ends of springs are tied to rigid supports, The displacement of the mass is  $x$  from equilibrium position. Which one of the following is TRUE ?

- (a) The force acting on the mass is  $-(k_1 k_2)^{1/2} x$   
 (b) The angular momentum of the mass is zero about the equilibrium point and its Lagrangian is

$$\frac{1}{2} m \dot{x}^2 - \frac{1}{2} (k_1 + k_2) x^2$$

- (c) The total energy of the system is  $\frac{1}{2} m \dot{x}^2$

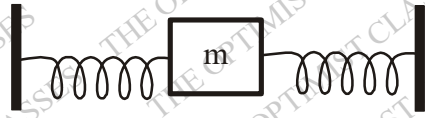

- (d) The angular momentum of the mass is  $m x \dot{x}$  and the Lagrangian of the system is  $\frac{m}{2} \dot{x}^2 + \frac{1}{2} (k_1 + k_2) x^2$

Q44. An electron gains energy so that its mass becomes  $2m_0$ . Its speed is

- (a)  $\frac{\sqrt{3}}{2} c$  (b)  $\frac{3}{4} c$  (c)  $\frac{3}{2} c$  (d)  $\sqrt{\frac{3}{2}} c$

Q45. A conducting sphere of radius  $R$  has charge  $+Q$  on its surface. If the charge on the sphere is doubled and its radius is halved, the energy associated with the electric field will

- (a) increase four times (b) increase eight times  
 (c) remain the same (d) decrease four times

Q46. A conducting sphere of radius  $R$  is placed in a uniform electric field  $\vec{E}_0$  directed along  $+z$  axis. The electric potential for outside points is given as  $V_{out} = -E_0 \left(1 - \frac{R^3}{r^3}\right) r \cos \theta$ , where  $r$  is the distance from the centre and

$\theta$  is the polar angle. The charge density on the surface of the sphere is

- (a)  $3\epsilon_0 E_0 \cos \theta$  (b)  $\epsilon_0 E_0 \cos \theta$  (c)  $3\epsilon_0 E_0 \cos \theta$  (d)  $\frac{\epsilon_0}{3} E_0 \cos \theta$

Q47. A circular arc QTS is kept in an external magnetic field  $\vec{B}_0$  as shown in figure. The arc carries a current  $I$ . The magnetic field is directed normal and into the page. The force acting on the arc is :

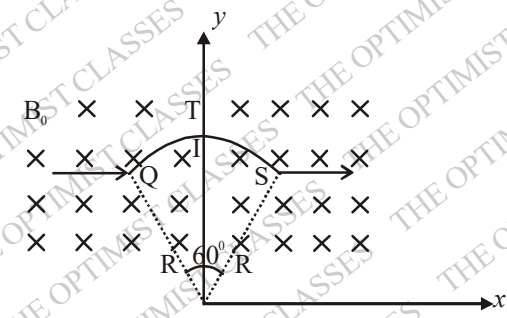

- (a)  $2IB_0R\hat{j}$       (b)  $IB_0R\hat{j}$       (c)  $-2IB_0R\hat{j}$       (d)  $-IB_0R\hat{j}$

Q48. A plane electromagnetic wave of frequency  $\omega$  is incident on an air-dielectric interface. The dielectric is linear, isotropic, non-magnetic and its refractive index is  $n$ . The reflectance ( $R$ ) and transmittance ( $T$ ) from the interface are

- (a)  $R = \left(\frac{n-1}{n+1}\right)^2, T = \frac{4n}{(n+1)^2}$       (b)  $R = -\left(\frac{n-1}{n+1}\right), T = \frac{2}{(n+1)^2}$   
 (c)  $R = -\left(\frac{n-1}{n+1}\right)^3, T = \frac{4n^3}{(n+1)^2}$       (d)  $R = -\left(\frac{n-1^2}{n+1}\right), T = \frac{4n^2}{(n+1)^2}$

Q49. The electric field of a plane e.m. wave is  $\vec{E} = \vec{E}_0 \exp[i(xk \cos \alpha + yk \sin \alpha - \omega t)]$ . If  $\hat{x}, \hat{y}$  and  $\hat{z}$  are cartesian unit vectors, the wave vector  $\hat{k}$  of the e.m. wave is

- (a)  $\hat{z}k$       (b)  $\hat{x}k \sin \alpha + \hat{y}k \cos \alpha$   
 (c)  $\hat{x}k \cos \alpha + \hat{y}k \sin \alpha$       (d)  $-\hat{z}k$

Q50. The dispersion relation for a low density plasma is  $\omega^2 = \omega_0^2 + c^2k^2$ , where  $\omega_0$  is the plasma frequency and  $c$  is the speed of light in free space. The relationship between the group velocity ( $v_g$ ) and phase velocity is

- (a)  $v_p = v_g$       (b)  $v_p = v_g^{1/2}$       (c)  $v_p v_g = c^2$       (d)  $v_g = v_p^{1/2}$

Q51. A Michelson interferometer is illuminated with monochromatic light, When one of the mirrors is moved through a distance  $25.3 \mu m$ , 92 fringes pass through the cross-wire. The wavelength of the monochromatic light is

- (a) 500 nm      (b) 550 nm      (c) 600 nm      (d) 650 nm

Q52. A beam of monoenergetic particles having speed  $v$  is described by the wave function  $\psi(x) = u(x) \exp(ikz)$ , where  $u(x)$  is a real function. This corresponds to a current density

- (a)  $u^2(x)v$       (b)  $v$       (c) zero      (d)  $u^2(x)$

Q53. The wave function of a spin-less particle of mass  $m$  in a one-dimensional potential  $V(x)$  is  $\psi(x) = A \exp(-\alpha^2 x^2)$  corresponding to an eigenvalue  $E_0 = \hbar^2 \alpha^2 / m$ . The potential  $V(x)$  is

- (a)  $2E_0(1 - \alpha^2 x^2)$       (b)  $2E_0(1 + \alpha^2 x^2)$       (c)  $2E_0 \alpha^2 x^2$       (d)  $2E_0(1 + 2\alpha^2 x^2)$

Q54. Two spin  $\vec{S}_1$  and  $\vec{S}_2$  interact via a potential  $V(r) = \vec{S}_1 \cdot \vec{S}_2 V_0(r)$ . The contributions of this potential in the singlet and triplet states, respectively, are

- (a)  $-\frac{3}{2}V_0(r)$  and  $\frac{1}{2}V_0(r)$       (b)  $\frac{1}{2}V_0(r)$  and  $-\frac{3}{2}V_0(r)$   
 (c)  $\frac{1}{4}V_0(r)$  and  $-\frac{3}{4}V_0(r)$       (d)  $-\frac{3}{4}V_0(r)$  and  $\frac{1}{4}V_0(r)$

Q55. The wave function of a one-dimensional harmonic oscillator is  $\psi_0 = A \exp\left(\frac{-\alpha^2 x^2}{2}\right)$  for the ground state

$E_0 = \frac{\hbar \omega}{2}$ , where  $\alpha^2 = \frac{m\omega}{\hbar}$ . In the presence of a perturbing of  $E_0 \left(\frac{\alpha x}{10}\right)^4$ , the first order change in the



ground state energy is: [Given:  $\Gamma(x+1) = \int_0^\infty t^x \exp(-t) dt$ ]

- (a)  $\left(\frac{1}{2} E_0\right) 10^{-4}$       (b)  $(3E_0) 10^{-4}$       (c)  $\left(\frac{3}{4} E_0\right) 10^{-4}$       (d)  $(E_0) 10^{-4}$

Q56. The  $L, S$  and  $J$  quantum numbers corresponding to the ground state electronic configuration of Boron ( $Z=5$ ) are

- (a)  $L=1, S=\frac{1}{2}, J=\frac{3}{2}$       (b)  $L=1, S=\frac{1}{2}, J=\frac{1}{2}$   
 (c)  $L=1, S=\frac{3}{2}, J=\frac{1}{2}$       (d)  $L=1, S=\frac{3}{2}, J=\frac{3}{2}$

Q57. The degeneracies of the  $J$ -states arising from the  $^3P$  term with spin-orbit interaction are

- (a) 1, 3, 5      (b) 1, 2, 3      (c) 3, 5, 7      (d) 2, 6, 10

Q58. Assuming that the L-S coupling scheme is valid, the number of permitted transitions from  $^2P_{3/2}$  to  $^2S_{1/2}$  due to a weak magnetic field is

- (a) 2      (b) 4      (c) 6      (d) 10

Q59. Consider the pure rotational spectrum of a diatomic rigid rotor. The separation between two consecutive lines ( $\Delta \bar{\nu}$ ) in the spectrum

- (a) is directly proportional to the moment of inertia of the rotor  
 (b) is inversely proportional to the moment of inertia of the rotor  
 (c) depends on the angular momentum  
 (d) is directly proportional to the square of the interatomic separation

Q60. Light of wavelength  $1.5 \mu m$  incident on a material with a characteristic Raman frequency of  $20 \times 10^{12}$  Hz results in a Stokes-shifted line of wavelength [Given:  $c = 3 \times 10^8 \text{ m}\cdot\text{s}^{-1}$ ]

- (a)  $1.47 \mu m$       (b)  $1.57 \mu m$       (c)  $1.67 \mu m$       (d)  $1.77 \mu m$

Q61. Consider black body radiation in a cavity maintained at  $2000 K$ . If the volume of the cavity is reversibly and adiabatically increased from  $10 \text{ cm}^3$  to  $640 \text{ cm}^3$ , the temperature of the cavity changes to

- (a)  $800 K$       (b)  $700 K$       (c)  $600 K$       (d)  $500 K$

Q62. The equation of state of a dilute gas at very high temperature is described by  $\frac{PV}{k_B T} \approx 1 + \frac{B(T)}{V}$ , where  $V$  is the volume per particle and  $B(T)$  is a negative quantity. One can conclude that this is a property of

- (a) a van der Waals gas      (b) an ideal Fermi gas  
 (c) an ideal Bose gas      (d) an ideal inert gas

Q63. In the region of co-existence of a liquid and vapor phase of a material

- (a)  $C_p$  and  $C_v$  both infinite.      (b)  $C_v$  and  $\beta = \left[ \frac{1}{V} \left( \frac{\partial V}{\partial T} \right)_p \right]$  are both finite.

- (c)  $C_v$  and  $K = \left[ -\frac{1}{V} \left( \frac{\partial V}{\partial P} \right)_T \right]$  are both finite.      (d)  $C_p, \beta$  and  $K$  are all infinite.

Q64. A doped Germanium crystal of length  $2 \text{ cm}$ , breadth  $1 \text{ cm}$  and width  $1 \text{ cm}$ , carries a current of  $1 \text{ mA}$  along its length parallel to  $+x$  axis. A magnetic field of  $0.5 T$  is applied along  $+z$  axis. Hall voltage of  $6 \text{ mV}$  is measured with negative polarity at  $y=0$  plane. The sign and concentration of the majority charge carrier are, respectively. [Given:  $e = 1.6 \times 10^{-19} C$ ]

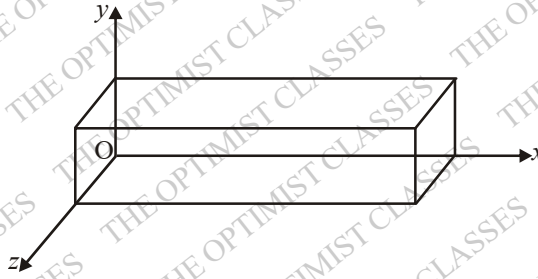

- (a) positive and  $5.2 \times 10^{19} \text{ m}^{-3}$  (b) negative and  $5.2 \times 10^{19} \text{ m}^{-3}$   
 (c) positive and  $10.4 \times 10^{19} \text{ m}^{-3}$  (d) negative and  $10.4 \times 10^{19} \text{ m}^{-3}$

Q65. The temperature dependence of the electrical conductivity  $\sigma$  of two intrinsic semiconductor  $A$  and  $B$  is shown in the figure. If  $E_A$  and  $E_B$  are the band gaps of  $A$  and  $B$  respectively, which one of the following is TRUE?

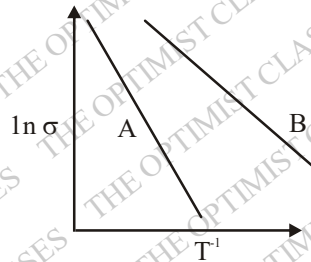

- (a)  $E_A > E_B$  (b)  $E_A < E_B$   
 (c)  $E_A = E_B$  (d)  $E_A$  and  $E_B$  both depend on temperature

Q66. If the static dielectric constant of NaCl crystal is 5.6 and its optical refractive index is 1.5, the ratio of its electric polarizability to its total polarizability is

- (a) 0.5 (b) 0.7 (c) 0.8 (d) 0.9

Q67. Which one of the following statements is TRUE ?

- (a) Magnetic tapes are made of Iron  
 (b) Permanent magnets are made from ferrites  
 (c) Ultrasonic transducers are made from quartz crystals  
 (d) Optoelectronic devices are made from soft ferrites

Q68. Which one of the following statements is NOT TRUE ?

- (a) Entropy decreases markedly on cooling a superconductor below the critical temperature,  $T_c$ .  
 (b) The electronic contribution to the heat capacity in the superconducting state has an exponential form with an argument proportional to  $T^{-1}$ , suggestive of an energy gap  
 (c) A type I superconductor is a perfect diamagnet  
 (d) Critical temperature of superconductor does not vary with the isotopic mass

Q69. The form factor  $F(\vec{q}) = \int \exp\left(i\vec{q} \cdot \frac{\vec{r}}{\hbar}\right) \rho(\vec{r}) d^3r$  of Rutherford scattering is obtained by choosing a delta

function for the charge density  $\rho(\vec{r})$ . The value of the form factor is

- (a) unity (b) infinity (c) zero (d) undefined

Q70. Deuteron in its ground state has a total angular momentum  $J=1$  and a positive parity. The corresponding orbital angular momentum  $L$  and spin  $S$  combination are

- (a)  $L=0, S=1$  and  $L=2, S=0$  (b)  $L=0, S=1$  and  $L=1, S=1$   
 (c)  $L=0, S=1$  and  $L=2, S=1$  (d)  $L=1, S=1$  and  $L=2, S=1$

Q71. Which one of the following reactions is allowed?

- (a)  $p \rightarrow n + e^+$  (b)  $p \rightarrow e^+ + \nu_e$  (c)  $p \rightarrow \pi^+ + \gamma$  (d)  $\bar{p} + n \rightarrow \pi^- + \pi^0$

Q72. What should be the values of the components  $R$  and  $R_2$  such that the frequency of the Wien Bridge oscillator is  $300 \text{ Hz}$  ?

[Given :  $C = 0.01 \mu\text{F}$  and  $R_1 = 12 \text{ k}\Omega$ ]

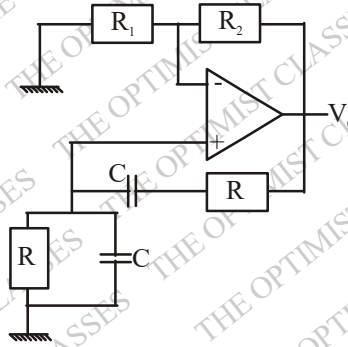

(a)  $R = 48 \text{ k}\Omega$  and  $R_2 = 12 \text{ k}\Omega$

(b)  $R = 26 \text{ k}\Omega$  and  $R_2 = 24 \text{ k}\Omega$

(c)  $R = 530 \Omega$  and  $R_2 = 1 \text{ M}\Omega$

(d)  $R = 53 \text{ k}\Omega$  and  $R_2 = 24 \text{ k}\Omega$

Q73. Figure shows a common emitter amplifier with  $\beta = 100$ . What is the maximum peak to peak input signal ( $v_s$ ) for which is distortion-free output may be obtained ?

[Assume  $V_{BE} = 0$  and  $r_e = 20 \Omega$ ]

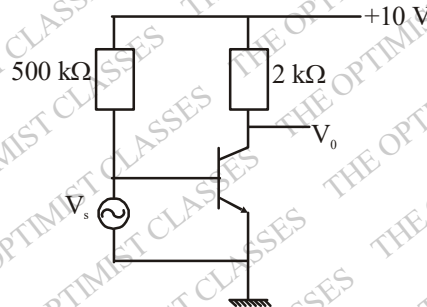

(a)  $40 \text{ mV}$

(b)  $60 \text{ mV}$

(c)  $80 \text{ mV}$

(d)  $100 \text{ mV}$

Q74. Calculate the collector voltage ( $V_C$ ) of the transistor circuit shown in the figure

[Given:  $\alpha = 0.96$ ,  $I_{CBO} = 20 \mu\text{A}$ ,  $V_{BE} = 0.3 \text{ V}$ ,  $R_B = 100 \text{ k}\Omega$ ,  $V_{CC} = +10 \text{ V}$  and  $R_C = 2.2 \text{ k}\Omega$ ]

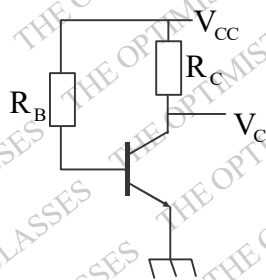

(a)  $3.78 \text{ V}$

(b)  $3.82 \text{ V}$

(c)  $4.72 \text{ V}$

(d)  $9.7 \text{ V}$

Q75. Figure shows a practical integrator with  $R_s = 30 \text{ M}\Omega$ ,  $R_f = 20 \text{ M}\Omega$  and  $C_f = 0.1 \mu\text{F}$ . If a step (dc) voltage of  $+3 \text{ V}$  is applied as input for  $0 \leq t \leq 4$  ( $t$  is in seconds), the output voltage is

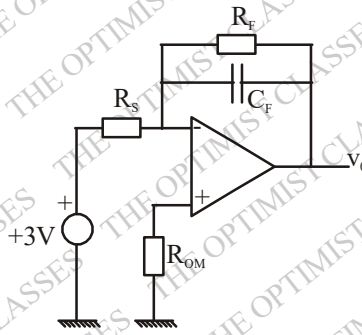

- (a) a ramp function of -6V  
 (b) a step function of -12V  
 (c) a ramp function of -15V  
 (d) a ramp function of -4V

Q76. The Boolean expression  $Y = \overline{ABC}D + \overline{AB}CD + \overline{A}B\overline{C}D + \overline{A}BCD$  reduces to

- (a)  $\overline{AB}$  (b) D (c)  $\overline{A}$  (d)  $\overline{AD}$

### Common Data for Q. 77 and Q. 78

Consider the differential equation  $y'' + p(x)y' + q(x)y = 0$ .

Q77. If  $xp(x)$  and  $x^2q(x)$  have the Taylor series expansions

$$xp(x) = 4 + x + x^2 + \dots$$

$$x^2q(x) = 2 + 3x + 5x^2 + \dots$$

then the roots of the indicial equation are

- (a) -1, 0 (b) -1, -2 (c) -1, 1 (d) -1, 2

Q78. If  $p(x) = 0$  with the Wronskian at  $x = 0$  as  $W(x = 0) = 1$  and one of the solution is  $x$ , then the other linearly independent solution which vanishes at  $x = 1/2$  is

- (a) 1 (b)  $1 - 4x^2$  (c)  $x$  (d)  $-1 + 2x$

### Common Data for Q. 79 and Q. 80

Consider a comet of mass  $m$  moving in a parabolic orbit around the Sun. The closest distance between the comet and the Sun is  $b$ , the mass of the Sun is  $M$  and the universal gravitation constant is  $G$ .

Q79. The angular momentum of the comet is

- (a)  $M\sqrt{Gmb}$  (b)  $b\sqrt{GmM}$  (c)  $G\sqrt{mMb}$  (d)  $m\sqrt{2Gmb}$

Q80. Which one of the following is TRUE for the above system?

- (a) The acceleration of the comet is maximum when it is closest to the Sun  
 (b) The linear momentum of the comet is a constant  
 (c) The comet will return to the solar system after a specified period  
 (d) The kinetic energy of the comet is a constant

### Common Data for Q.81 and Q.82

Let  $\vec{E} = \hat{x}E_0 \exp[i\vec{k} \cdot \vec{r} - \omega t]$ , where  $\vec{k} = \hat{z}(k \cos \phi + ik \sin \phi)$ ,  $k = 1/\lambda$  and  $\hat{x}$ ,  $\hat{y}$  and  $\hat{z}$  are cartesian unit vectors, represent an electric field of a plane electro magnetic wave of frequency  $\omega$ .

Q81. Which one of the following statements is TRUE?

- (a) The magnitude of the electric field is attenuated as the wave propagates  
 (b) The energy of the e.m. wave flows along the x-direction  
 (c) The magnitude of the electric field of the wave is a constant  
 (d) The speed of the wave is the same as  $c$  (speed of light in free space)

Q82. The magnetic field  $\vec{B}$  of the wave is :

(a)  $\hat{y} \frac{k}{\omega} E_0 \exp(-zk \sin \phi) \exp[i(zk \cos \phi - \omega t)]$

(b)  $\hat{y} \frac{k}{\omega} E_0 \exp(-zk \sin \phi) \exp[i(zk \cos \phi - \omega t + \phi)]$

(c)  $\hat{y} \frac{k}{\omega} E_0 \exp[i(zk \cos \phi - \omega t + \phi)]$

(d)  $\hat{y} \frac{k}{\omega} E_0 \exp(-zk \cos \phi) \exp[i(zk \cos \phi - \omega t)]$

**Common data for Q.83 and Q.84**

A particle is confined to the region  $0 < x < L$  in one dimension.

Q83. If the particle is in the first excited state, then the probability of finding the particle is maximum at

(a)  $x = \frac{L}{6}$

(b)  $x = \frac{L}{2}$

(c)  $x = \frac{L}{3}$

(d)  $x = \frac{L}{4}$  and  $\frac{3L}{4}$

Q84. If the particle is in the lowest energy state, then the probability of finding the particle in the region  $0 < x < \frac{L}{4}$  is:

(a)  $\frac{1}{4} - \frac{1}{(2\pi)}$

(b)  $\frac{1}{4}$

(c)  $\frac{1}{4} + \frac{1}{(2\pi)}$

(d)  $\frac{1}{2}$

**Common data for Q.85 and Q.86**

The one-electron states for non-interacting electrons confined in a cubic box of side  $a$  are  $\epsilon_0 < \epsilon_1 < \epsilon_2 < \epsilon_3 < \epsilon_4$  etc.

Q85. The energy of the lowest state is:

(a) zero

(b)  $\frac{\hbar^2 \pi^2}{2ma^2}$

(c)  $\frac{\hbar^2 \pi^2}{ma^2}$

(d)  $\frac{3\hbar^2 \pi^2}{2ma^2}$

Q86. The degeneracy (including spin) of the level  $\epsilon_3$  is

(a) 2

(b) 4

(c) 6

(d) 8

**Common data for Q.87 and Q.88**

An ensemble of  $N$  three-level systems with energies  $\epsilon = -\epsilon_0, 0, +\epsilon_0$  is in thermal equilibrium at temperature

$T$ . Let  $\beta = (k_B T)^{-1}$

Q87. If  $\beta\epsilon_0 = 2$ , the probability of finding the system in the level  $\epsilon = 0$  is:

(a)  $(\cosh 2) / 2$

(b)  $(\cosh 2)^{-1}$

(c)  $(2 \cosh 2)^{-1}$

(d)  $(1 + 2 \cosh 2)^{-1}$

Q88. The free energy of the system at high temperature (i.e.,  $x \equiv \beta\epsilon_0 \ll 1$ ) is approximately

(a)  $-Nk_B T x^2$

(b)  $-Nk_B T [1 \ln 2 + x^2 / 2]$

(c)  $-Nk_B T [1 \ln 3 + x^2 / 3]$

(d)  $-Nk_B T \ln 3$

**Common Data for Q.89 and Q.90 :**

The nucleus  $^{41}\text{Ca}$  can be described by the single particle shell model.

Q89. The single particle states occupied by the last proton and the last neutron, respectively, are given by

- (a)  $d_{5/2}$  and  $f_{7/2}$       (b)  $d_{3/2}$  and  $f_{5/2}$       (c)  $d_{5/2}$  and  $f_{5/2}$       (d)  $d_{3/2}$  and  $f_{7/2}$

Q90. The ground state angular momentum and parity of  $^{41}\text{Ca}$  are

- (a)  $\frac{7^-}{2}$       (b)  $\frac{3^+}{2}$       (c)  $\frac{5^+}{2}$       (d)  $\frac{5^-}{2}$

**ANSWER KEY**

- |         |         |         |         |         |
|---------|---------|---------|---------|---------|
| 1. (d)  | 2. (b)  | 3. (c)  | 4. (c)  | 5. (a)  |
| 6. (b)  | 7. (c)  | 8. (d)  | 9. (b)  | 10. (c) |
| 11. (a) | 12. (d) | 13. (d) | 14. (b) | 15. (b) |
| 16. (d) | 17. (a) | 18. (a) | 19. (d) | 20. (c) |
| 21. (c) | 22. (c) | 23. (a) | 24. (b) | 25. (a) |
| 26. (a) | 27. (c) | 28. (a) | 29. (c) | 30. (d) |
| 31. (d) | 32. (c) | 33. (d) | 34. (b) | 35. (c) |
| 36. (c) | 37. (b) | 38. (a) | 39. (b) | 40. (b) |
| 41. (c) | 42. (d) | 43. (b) | 44. (a) | 45. (b) |
| 46. (c) | 47. (b) | 48. (a) | 49. (c) | 50. (c) |
| 51. (b) | 52. (a) | 53. (c) | 54. (d) | 55. (c) |
| 56. (b) | 57. (a) | 58. (c) | 59. (b) | 60. (c) |
| 61. (d) | 62. (a) | 63. (a) | 64. (b) | 65. (a) |
| 66. (a) | 67. (a) | 68. (d) | 69. (a) | 70. (c) |
| 71. (d) | 72. (d) | 73. (d) | 74. (a) | 75. (d) |
| 76. (d) | 77. (b) | 78. (d) | 79. (d) | 80. (a) |
| 81. (a) | 82. (b) | 83. (d) | 84. (a) | 85. (d) |
| 86. (c) | 87. (d) | 88. (d) | 89. (d) | 90. (a) |