

# THE OPTIMIST CLASSES IIT-JAM TOPPERS



**MANOJ KUMAR SINGH**



**ABHAY**



**PAWAN**



**SATYAM**



**SOUMIL GIRISH SAHU**



**BHOOMIJA**



**AKSHIT AGGARWAL**



**SHIKHAR CHAMOLI**



**RAVI SINGH ADHIKARI**



**GAURAV JHA**



**SWAPNIL JOSHI**



**LOKESH BHATT**



**GOPESH VISHVAKARMA**



**VAIBHAV**



**SHASWAT CHAMOLI**

# CSIR-NET-JRF RESULTS 2022



**ANNU**  
DL01000308

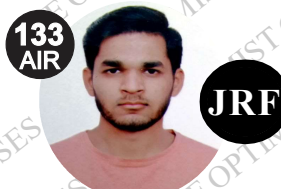

**ALANKAR**  
UP15000162



**SAHIL RANA**  
HR09000108



**JAYESTHI**  
RJ11000161



**DASRATH**  
RJ06000682



**VIVEK**  
UK01000439



**UZAIR AHMED**  
UP02000246



**SURYA PRATAP SINGH**  
RJ06000232



**HIMANSHU**  
UP10000095



**CHANDAN**  
RJ09000159



**SAIKHOM JOHNSON**  
MN01000196



**AJAY SAINI**  
RJ06001744



**VIKAS YADAV**  
RJ06001102



**JYOTSNA KOHLI**  
UK02000262



**SHYAM SUNDAR**  
RJ06000615

# THE OPTIMIST CLASSES

AN INSTITUTE FOR NET-JRF/GATE/IIT-JAM/JEST/TIFR/M.Sc ENTRANCE EXAMS

CONTACT: 9871044043

## GATE PAPER 2021

1.  $\oplus$  and  $\odot$  are two operators on numbers  $p$  and  $q$  such that  $p \odot q = p - q$  and  $p \oplus q = p \times q$ .

Then,  $(9 \odot (6 \oplus 7)) \odot (\oplus (6 \odot 5)) =$

- (a) -40                      (b) -26  
(c) 40                        (d) -33

2. In the figure shown above,  $PQRS$  is a square. The shaded portion is formed by the intersection of sectors of circles with radius equal to the side of the square and centers at  $S$  and  $Q$ .

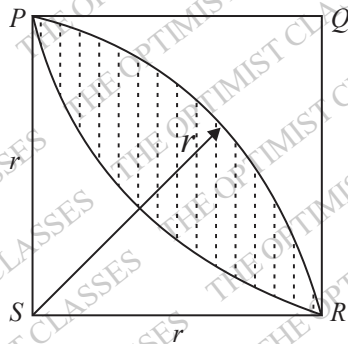

The probability that any point picked randomly within the square falls in the shaded area is

- (a)  $\frac{1}{2}$                         (b)  $\frac{\pi}{2} - 1$   
(c)  $\frac{\pi}{4}$                         (d)  $4 - \frac{\pi}{2}$

3. (1) Arun and Aparna are here.  
(2) Arun and Aparna is here.  
(3) Arun's families is here.  
(4) Arun's family is here.

Which of the above sentences are grammatically CORRECT?

- (a) (3) and (4)                      (b) (1) and (4)  
(c) (1) and (2)                      (d) (2) and (4)

4. The author said, "Musicians rehearse before their concerts. Actors rehearse their roles before the opening of a new play. On the other hand, I find it strange that many public speakers think they can just walk on to the stage and start speaking. In my opinion, it is no less important for public speakers to rehearse their talks".

Based on the above passage, which one of the following is TRUE?

- (a) the author is of the opinion that rehearsing is less important for public speakers than for musicians and actors.  
(b) The author is of the opinion that rehearsal is more important for actors than musicians.  
(c) The author is of the opinion that rehearsing is more important only for musicians than public speakers.  
(d) The author is of the opinion that rehearsing is important for musicians, actors and public speakers.

5. On a planar field, you travelled 3 units East from a point  $O$ . Next you travelled 4 units South to arrive at point  $P$ . Then you travelled from  $P$  in the North-East direction such that you arrive at a point that is 6 units East of point  $O$ . Next, you travelled in the North-West direction, so that you arrive at point  $Q$  that is 8 units North of point  $P$ .

The distance of point  $Q$  to point  $O$ , in the same units, should be

- (a) 3                                      (b) 6  
(c) 5                                      (d) 4

6. 1. Some football players play cricket.

2. All cricket players play hockey.

Among the options given below, the statement that logically follows from the two statements 1 and 2 above, is:

- (a) All hockey players play football.  
 (b) All football players play hockey.  
 (c) No football players play hockey.  
 (d) Some football players play hockey.

7. In an equilateral triangle  $PQR$ , side  $PQ$  is divided into four equal parts, side  $QR$  is divided into six equal parts and side  $PR$  is divided into eight equal parts. The length of each subdivided part in cm is an integer. The minimum area of the triangle  $PQR$  possible, in  $cm^2$ , is

- (a)  $48\sqrt{3}$  (b) 18  
 (c) 24 (d)  $144\sqrt{3}$

8. Four persons  $P, Q, R$  and  $S$  are to be seated in a row,  $R$  should not be seated at the second position from the left end of the row. The number of distinct seating arrangements possible is

- (a) 18 (b) 9  
 (c) 24 (d) 6

9. Two identical cube shaped dice each with faces numbered 1 to 6 are rolled simultaneously. The probability that an even number is rolled out on each dice is:

- (a)  $1/8$  (b)  $1/36$   
 (c)  $1/4$  (d)  $1/12$

10. The mirror image of the below text about the  $x$ -axis is

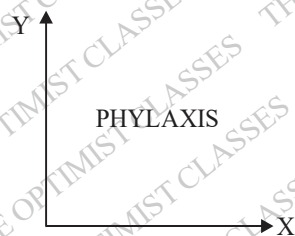

- (a) PH  $\lambda$  J AXI  $\lambda$  (b)  $\beta$  H  $\lambda$   $\Gamma$   $\Delta$  XI  $\lambda$   
 (c)  $\beta$  H  $\lambda$   $\Gamma$   $\Delta$  XI  $\lambda$  (d)  $\beta$  H  $\lambda$   $\Gamma$   $\Delta$  XI  $\lambda$

### SECTION : PHYSICS

1. The below combination of logic gates represents the operation

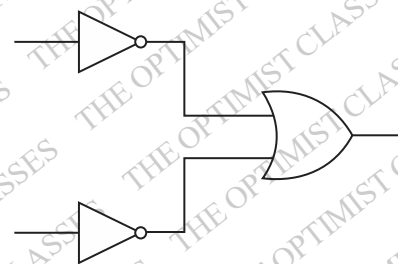

- (a) AND (b) NOR  
 (c) OR (d) NAND

2. To sustain lasing action in a three-level laser as shown in the figure necessary condition(s) is(are)

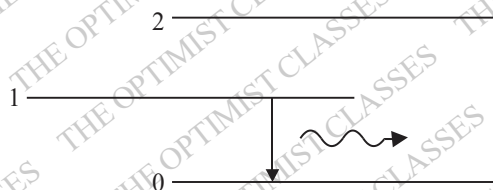

- (a) lifetime of the energy level 2 should be greater than that of energy level 0.  
 (b) lifetime of the energy level 1 should be greater than that of energy level 2.  
 (c) population of the particles in level 1 should be greater than that of level 0.  
 (d) population of the particles in level 2 should be greater than that of level 1.

3. Consider the potential  $U(r)$  defined as:

$$U(r) = -U_0 \frac{e^{-\alpha r}}{r}$$

where  $\alpha$  and  $U_0$  are real constants of appropriate dimensions. According to the first Born approximation, the elastic scattering amplitude calculated with  $U(r)$  for a (wave-vector) momentum transfer  $q$  and  $\alpha \rightarrow 0$ , is proportional to

$$\text{Useful integral: } \int_0^{\infty} \sin(qr) e^{-\alpha r} dr = \frac{q}{\alpha^2 + q^2}$$

- (a)  $q^{-2}$  (b)  $q^2$   
 (c)  $q^{-1}$  (d)  $q$

4. Consider a system of three distinguishable particles, each having spin  $S = \frac{1}{2}$  such that

$$S_z = \pm \frac{1}{2} \text{ with corresponding magnetic moments}$$

$\mu_z = \pm \mu$ . When the system is placed in an external magnetic field  $H$  pointing along the  $z$ -axis, the total energy of the system is  $\mu H$ . Let  $x$  be the

state where the first spin has  $S_z = \frac{1}{2}$ . The probability of having the state  $x$  and the mean magnetic moment (in the  $+z$  direction) of the system in state  $x$  are

- (a)  $\frac{2}{3}, \frac{-2}{3}\mu$       (b)  $\frac{2}{3}, \frac{1}{3}\mu$   
 (c)  $\frac{1}{3}, \frac{2}{3}\mu$       (d)  $\frac{1}{3}, \frac{-1}{3}\mu$

5. Consider a tiny current loop driven by a sinusoidal alternating current. If the surface integral of its time-averaged Poynting vector is constant, then the magnitude of the time-averaged magnetic field intensity, at any arbitrary position,  $\vec{r}$ , is proportional to

- (a)  $\frac{1}{r^2}$       (b)  $r$   
 (c)  $\frac{1}{r}$       (d)  $\frac{1}{r^3}$

6. A light source having its intensity peak at the wavelength  $289.8\text{nm}$  is calibrated as  $10,000\text{K}$  which is the temperature of an equivalent black body radiation. Considering the same calibration, the temperature of light source (in  $\text{K}$ ) having its intensity peak at the wavelength  $579.6\text{nm}$  (rounded off to the nearest integer) is \_\_\_\_\_.

7. As shown in the figure, X-ray diffraction pattern is obtained from a diatomic chain of atoms  $P$  and  $Q$ . The diffraction condition is given by  $a \cos \theta = n\lambda$ , where  $n$  is the order of the diffraction peak. Here  $a$  is the lattice constant and  $\lambda$  is the wavelength of the X-rays. Assume that atomic form factors and resolution of the instrument do not depend on  $\theta$ . Then, the intensity of the diffraction peaks is

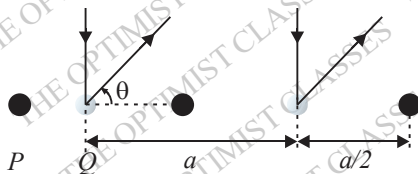

- (a) lower for even values of  $n$ , when compared to odd values of  $n$ .  
 (b) zero for even values of  $n$ .  
 (c) lower for odd values of  $n$ , when compared to even values of  $n$ .  
 (d) zero for odd values of  $n$ .

8. Consider a solenoid of length  $L$  and radius  $R$ , where  $R \ll L$ . A steady current flows through the

solenoid. The magnetic field is uniform inside the solenoid and zero outside.

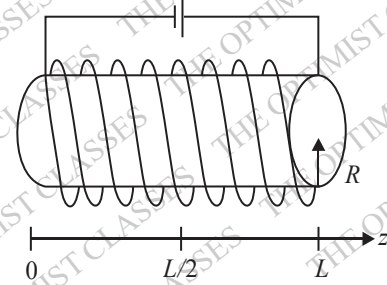

Among the given options, choose the one that best represents the variation in the magnitude of the vector potential  $(0, A_\phi, 0)$  at  $z = \frac{L}{2}$ , as a function of the radial distance ( $r$ ) in cylindrical coordinates.

Useful information: The curl of a vector  $\vec{F}$ , in cylindrical coordinates is

$$\vec{\nabla} \times \vec{F}(r, \phi, z) = \hat{r} \left[ \frac{1}{r} \frac{\partial F_z}{\partial \phi} - \frac{\partial F_\phi}{\partial z} \right] + \hat{\phi} \left[ \frac{\partial F_r}{\partial z} - \frac{\partial F_z}{\partial r} \right] + \hat{z} \left[ \frac{\partial (rF_\phi)}{\partial r} - \frac{\partial F_r}{\partial \phi} \right]$$

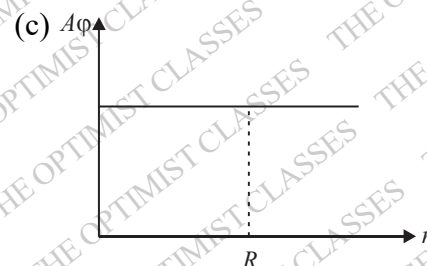
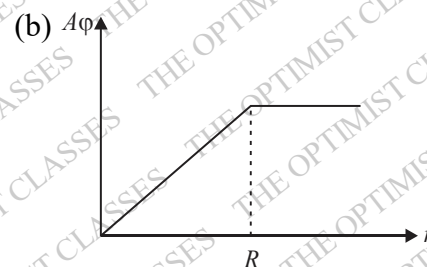
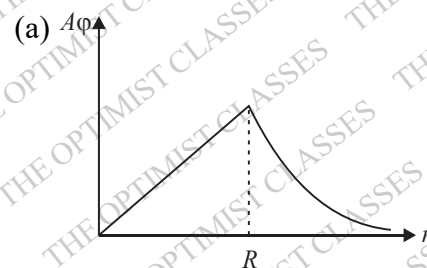

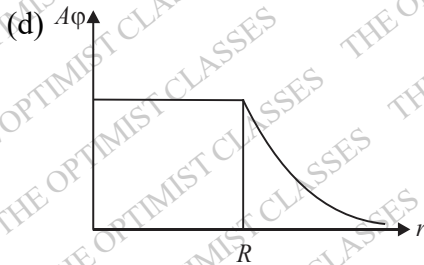

9. For a finite system of Fermions where the density of states increases with energy, the chemical potential
- increases with temperature
  - decreases with temperature
  - corresponds to the energy where the occupation probability is 0.5.
  - does not vary with temperature
10. Consider a point charge  $+Q$  of mass  $m$  suspended by a massless, inextensible string of length  $l$  in free space (permittivity  $\epsilon_0$ ) as shown in the figure. It is placed at a height  $d$  ( $d > l$ ) over an infinitely large, grounded conducting plane. The gravitational potential energy is assumed to be zero at the position of the conducting plane and is positive above the plane.

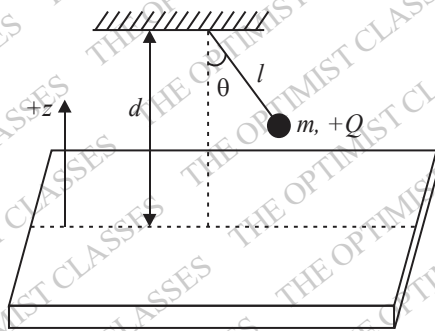

If  $\theta$  represents the angular position and  $p_\theta$  its corresponding canonical momentum, then the correct Hamiltonian of the system is

- $\frac{p_\theta^2}{2ml^2} - \frac{Q^2}{8\pi\epsilon_0(d-l\cos\theta)} + mg(d-l\cos\theta)$
  - $\frac{p_\theta^2}{2ml^2} - \frac{Q^2}{8\pi\epsilon_0(d-l\cos\theta)} - mg(d-l\cos\theta)$
  - $\frac{p_\theta^2}{2ml^2} - \frac{Q^2}{16\pi\epsilon_0(d-l\cos\theta)} + mg(d-l\cos\theta)$
  - $\frac{p_\theta^2}{2ml^2} - \frac{Q^2}{16\pi\epsilon_0(d-l\cos\theta)} - mg(d-l\cos\theta)$
11. Consider the atomic system as shown in the figure,

where the Einstein  $A$  co-efficients for spontaneous emission for the levels are  $A_{2 \rightarrow 1} = 2 \times 10^7 \text{ sec}^{-1}$  and  $A_{1 \rightarrow 0} = 10^8 \text{ sec}^{-1}$ .

If  $10^{14}$  atoms /  $\text{cm}^3$  are excited from level 0 to level 2 and a steady state population in level 2 is achieved, then the steady state population at level 1 will be  $x \times 10^{13} \text{ cm}^{-3}$ . The value of  $x$  (in integer) is

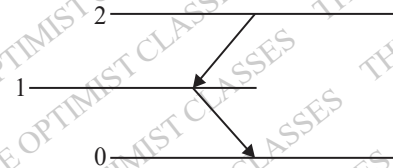

12. If  $\vec{a}$  and  $\vec{b}$  are constant vectors,  $\vec{r}$  and  $\vec{p}$  are generalized positions and conjugate momenta, respectively, then for the transformation  $Q \equiv \vec{a} \cdot \vec{p}$  and  $P \equiv \vec{b} \cdot \vec{r}$  to be canonical, the value of  $\vec{a} \cdot \vec{b}$  (in integer) is \_\_\_\_\_.
13. Consider an atomic gas with number density  $n = 10^{20} \text{ m}^{-3}$ , in the ground state at  $300\text{K}$ . The valence electronic configuration of atoms is  $f^7$ . The paramagnetic susceptibility of the gas  $\chi = m \times 10^{-11}$ . The value of  $m$  (rounded off to two decimal places) is \_\_\_\_\_.
- (Given : Magnetic permeability of free space  $\mu_0 = 4\pi \times 10^{-7} \text{ Hm}^{-1}$   
Bohr magneton  $\mu_B = 9.274 \times 10^{-24} \text{ Am}^2$   
Boltzmann constant  $k_B = 1.3807 \times 10^{-23} \text{ JK}^{-1}$ )
14. For the given sets of energy levels of nuclei  $X$  and  $Y$  whose mass number are odd and even, respectively choose the best suited interpretation.

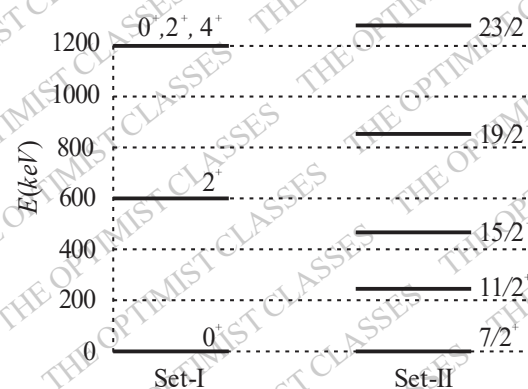

- (a) Set-I : Vibrational band of  $X$   
Set-II : Rotational band of  $Y$

- (b) Set-I : Rotational band of  $Y$   
 Set-II : Vibrational band of  $X$   
 (c) Set-I : Rotational band of  $X$   
 Set-II : Vibrational band of  $Y$   
 (d) Set-I : Vibrational band of  $Y$   
 Set-II : rotational band of  $X$

15. As shown in the figure, inverse magnetic suscepti-

bility  $\left(\frac{1}{\chi}\right)$  is plotted as a function of temperature ( $T$ ) for three differential materials in paramagnetic states.

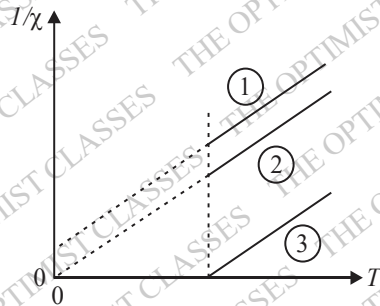

(Curie temperature of ferromagnetic material =  $T_C$ )  
 Chose the correct statement from the following.

- (a) Material 1 is ferromagnetic ( $T < T_C$ ), 2 is paramagnetic and 3 is antiferromagnetic ( $T < T_N$ ).  
 (b) Material 1 is paramagnetic, 2 is antiferromagnetic ( $T < T_N$ ) and 3 is ferromagnetic ( $T < T_C$ ).  
 (c) Material 1 ferromagnetic ( $T < T_C$ ), 2 is antiferromagnetic ( $T < T_N$ ), and 3 is paramagnetic.  
 (d) Material 1 is antiferromagnetic ( $T < T_N$ ), 2 is paramagnetic, and 3 is ferromagnetic ( $T < T_C$ ).

16. The normalized radial wave function of the second excited state of Hydrogen atom is

$$R(r) = \frac{1}{\sqrt{24}} \left( a^{-3/2} \right) \frac{r}{a} \left( e^{-r/2a} \right)$$

where  $a$  is the Bohr radius  $r$  is the distance from the centre of the atom. The distance at which the electron is most likely to be found is  $y \times a$ . The value of  $y$  (in integer) is \_\_\_\_\_.

17. Consider a cross-section of an electromagnet having an air-gap of  $5\text{cm}$  as shown in the figure. It consists of a magnetic material ( $\mu = 20000\mu_0$ ) and is driven by a coil having  $NI = 10^4 \text{ A}$ , where  $N$  is the number of turns and  $I$  is the current in Ampere

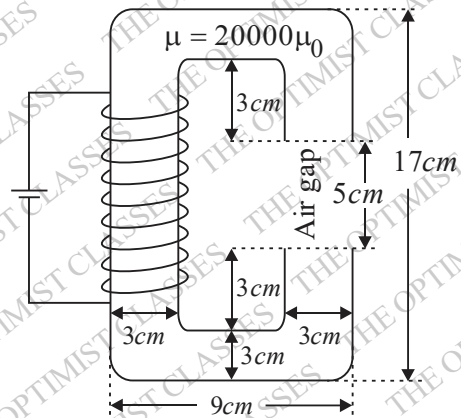

Ignoring the fringe fields, the magnitude of the magnetic field  $\vec{B}$  (in Tesla, rounded off to two decimal places) in the air-gap between the magnetic poles is \_\_\_\_\_

18. A system of two atoms can be in three quantum state having energies  $0, \epsilon$  and  $2\epsilon$ . The system is in equilibrium at temperature  $T = (k_B \beta)^{-1}$ . Match the following statistics with the partition function.

Statistics	Partition function
<b>CD:</b> Classical (distinguishable particles)	<b>Z1:</b> $e^{-\beta\epsilon} + e^{-2\beta\epsilon} + e^{-3\beta\epsilon}$
<b>CI:</b> Classical (indistinguishable particles)	<b>Z2:</b> $1 + e^{-\beta\epsilon} + 2e^{-2\beta\epsilon} + e^{-3\beta\epsilon} + e^{-4\beta\epsilon}$
<b>FD:</b> Fermi Dirac	<b>Z3:</b> $1 + 2e^{-\beta\epsilon} + 3e^{-2\beta\epsilon} + 2e^{-3\beta\epsilon} + e^{-4\beta\epsilon}$
<b>BE:</b> Bose -Einstein	<b>Z4:</b> $\frac{1}{2} + e^{-\beta\epsilon} + \frac{3}{2}e^{-2\beta\epsilon} + e^{-3\beta\epsilon} + \frac{1}{2}e^{-4\beta\epsilon}$

- (a) CD : Z1, CI : Z2, FD : Z3, BE : Z4  
 (b) CD : Z2, CI : Z3, FD : Z4, BE : Z1  
 (c) CD : Z4, CI : Z1, FD : Z2, BE : Z3  
 (d) CD : Z3, CI : Z4, FD : Z1, BE : Z2

19. Choose the graph that best describes the variation of dielectric constant ( $\epsilon_r$ ) with temperature ( $T$ ) in a ferro-electric material. ( $T_C$  is the Curie temperature)

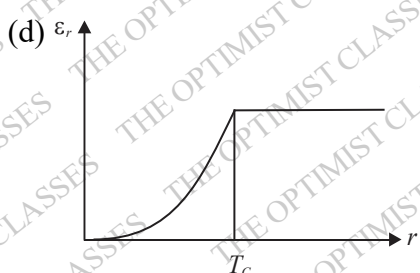
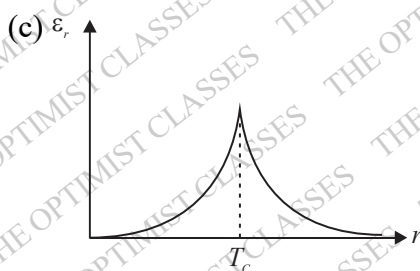
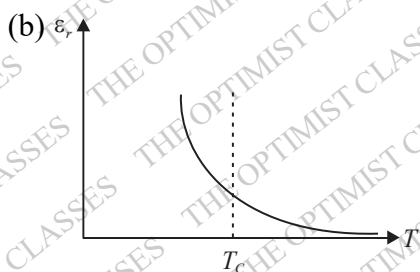
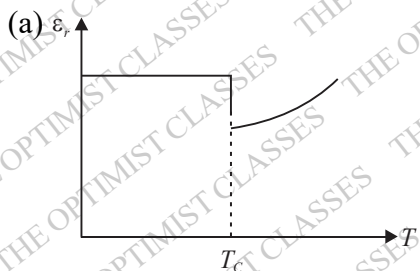

$x$ , then acceptable plot(s) of  $\psi_n(x) = e^{-x/2} y_n(x)$  is(are)

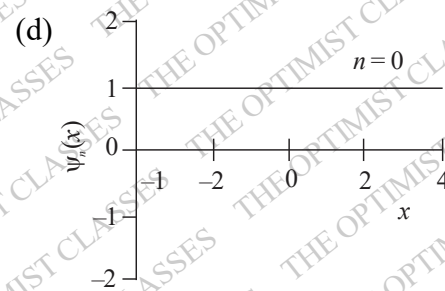
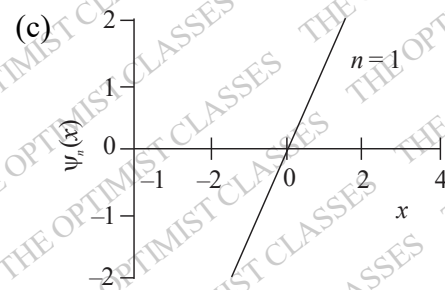
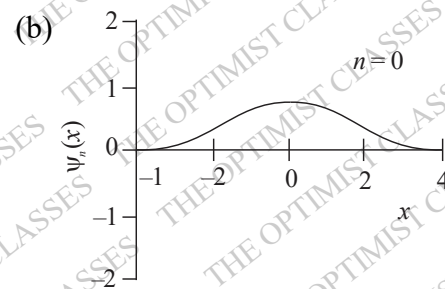
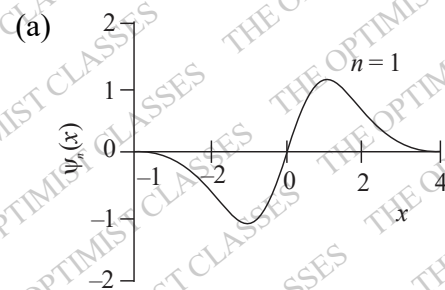

20. The spin-orbit effect splits the  $^2P \rightarrow ^2S$  transition (wavelength,  $\lambda = 62521 \text{ \AA}$ ) in Lithium into two lines with separation of  $\Delta\lambda = 0.14 \text{ \AA}$ . The corresponding positive value of energy difference between the above two lines, in  $eV$ , is  $m \times 10^{-5}$ . The value of  $m$  (rounded off to the nearest integer) is \_\_\_\_\_.

[Given: Planck's constant,

$h = 4.125 \times 10^{-15} eV \cdot \text{sec}$ , speed of light,  $c = 3 \times 10^8 m \text{ sec}^{-1}$ ].

21. If  $y_n(x)$  is a solution of the differential equation  $y'' - 2xy' - 2ny = 0$  where  $n$  is an integer and the prime (') denotes differentiation with respect to

22. Consider a spin  $S = \frac{\hbar}{2}$  particle in the state

$$|\phi\rangle = \frac{1}{3} \begin{bmatrix} 2+i \\ 2 \end{bmatrix}. \text{ The probability that a measure-}$$

ment finds the state with  $S_x = +\frac{\hbar}{2}$  is



(a)  $\frac{17}{18}$

(b)  $\frac{5}{18}$

(c)  $\frac{15}{18}$

(d)  $\frac{11}{18}$

23. Consider a state described by  $\psi(x, t) = \psi_2(x, t) + \psi_4(x, t)$ , where  $\psi_2(x, t)$  and  $\psi_4(x, t)$  are respectively the second and fourth normalized harmonic oscillator wave functions and  $\omega$  is the angular frequency of the harmonic oscillator. The wave function  $\psi(x, t) = 0$  will be orthogonal to  $\psi(x, t)$  at time  $t$  equal to

(a)  $\frac{\pi}{2\omega}$

(b)  $\frac{\pi}{4\omega}$

(c)  $\frac{\pi}{6\omega}$

(d)  $\frac{\pi}{\omega}$

24. Choose the correct statement from the following  
 (a) Gallium Arsenide is an indirect band gap semiconductor  
 (b) Conductivity of semiconductor decreases with increase in temperature  
 (c) Silicon is a direct band gap semiconductor  
 (d) Conductivity of metals decreases with increase in temperature

25. A two-dimensional square lattice has lattice constant  $a$ .  $k$  represents the wavevector in reciprocal space. The coordinates  $(k_x, k_y)$  of reciprocal space where band gap(s) can occur, are

(a)  $\left(\pm \frac{\pi}{a}, \pm \frac{\pi}{1.3a}\right)$

(b)  $\left(\pm \frac{\pi}{a}, \pm \frac{\pi}{a}\right)$

(c)  $\left(\pm \frac{\pi}{3a}, \pm \frac{\pi}{a}\right)$

(d)  $(0, 0)$

26. A matter wave is represented by the wave function:  $\psi(x, y, z, t) = Ae^{i(4x+3y+5z-10\pi t)}$  where  $A$  is a constant. The unit vector representing the direction of propagation of this matter wave is

(a)  $\frac{4}{5\sqrt{2}}\hat{x} + \frac{3}{5\sqrt{2}}\hat{y} + \frac{1}{\sqrt{2}}\hat{z}$

(b)  $\frac{1}{5\sqrt{2}}\hat{x} + \frac{3}{5\sqrt{2}}\hat{y} + \frac{1}{\sqrt{2}}\hat{z}$

(c)  $\frac{3}{5\sqrt{2}}\hat{x} + \frac{4}{5\sqrt{2}}\hat{y} + \frac{1}{5\sqrt{2}}\hat{z}$

(d)  $\frac{1}{5\sqrt{2}}\hat{x} + \frac{4}{5\sqrt{2}}\hat{y} + \frac{3}{5\sqrt{2}}\hat{z}$

27. A material is placed in a magnetic field intensity  $\vec{H}$ . As a result, bound current density  $\vec{J}_b$  is induced and magnetization of the material is  $\vec{M}$ . The magnetic flux density is  $\vec{B}$ . Choose the correct option(s) valid at the surface of the material.  
 (a)  $\vec{\nabla} \cdot \vec{H} = 0$  (b)  $\vec{\nabla} \cdot \vec{B} = 0$   
 (c)  $\vec{\nabla} \cdot \vec{J}_b = 0$  (d)  $\vec{\nabla} \cdot \vec{M} = 0$

28. Assume that  $^{13}\text{N}$  ( $Z = 7$ ) undergoes first forbidden  $\beta^+$  decay from its ground state with spin-parity  $J_i^\pi$ , to a final state  $J_f^\pi$ . The possible values for  $J_i^\pi$  and  $J_f^\pi$ , respectively, are

(a)  $\frac{1^-}{2}, \frac{1^-}{2}$

(b)  $\frac{1^-}{2}, \frac{5^+}{2}$

(c)  $\frac{1^+}{2}, \frac{5^+}{2}$

(d)  $\frac{1^+}{2}, \frac{1^-}{2}$

29. A uniform block of mass  $M$  slides on a smooth horizontal bar. Another mass  $m$  is connected to it by an inextensible string of length  $l$  of negligible mass, and is constrained to oscillate in the  $X$ - $Y$  plane only. Neglect the sizes of the masses. The number of degrees of freedom of the system is two and the generalized coordinates are chosen as  $x$  and  $\theta$  as shown in the figure.

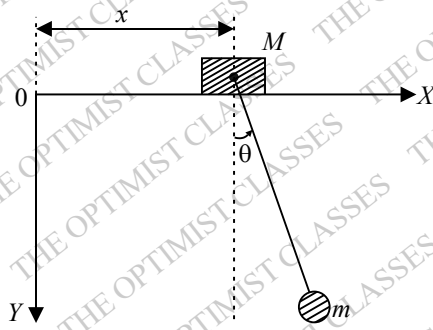

If  $p_x$  and  $p_\theta$  are the generalized momenta corresponding to  $x$  and  $\theta$ , respectively, then the correct option(s) is(are)

- (a)  $p_\theta$  is conserved  
 (b)  $p_\theta = ml^2\dot{\theta} - ml \cos \theta \dot{x}$   
 (c)  $p_x$  is conserved  
 (d)  $p_x = (m + M)\dot{x} + ml \cos \theta \dot{\theta}$

30. In a semiconductor, the ratio of the effective mass of hole to electron is 2 : 1 and the ratio of average relaxation time for hole to electron is 1 : 2. The ratio of the mobility of the hole to electron is

- (a) 4 : 9                      (b) 11 : 4  
 (c) 4 : 11                     (d) 9 : 4

31. The free energy of a ferromagnet is given by  $F = F_0 + a_0(T - T_C)M^2 + bM^4$ , where  $F_0$ ,  $a_0$  and  $b$  are positive constants,  $M$  is the magnetization,  $T$  is the temperature, and  $T_C$  is the Curie temperature. The relation between  $M^2$  and  $T$  is best depicted by

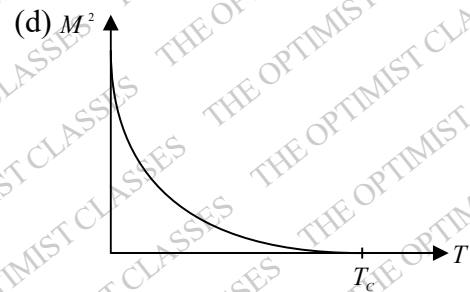
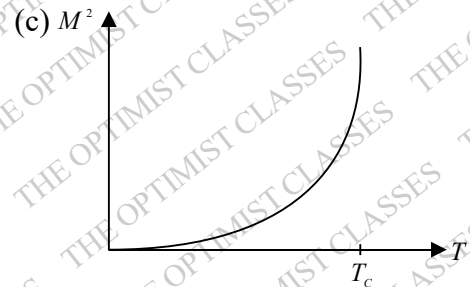
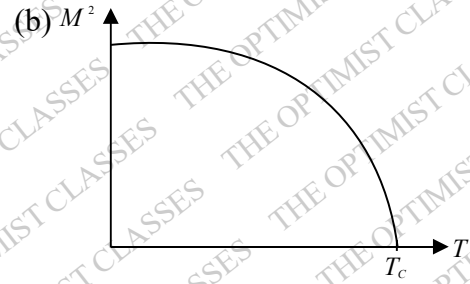
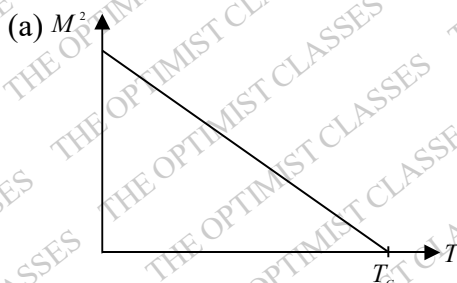

32. As shown in the figure, an electromagnetic wave with intensity  $I_i$  is incident at the interface of two media having refractive indices  $n_1 = 1$  and  $n_2 = \sqrt{3}$ . The wave is reflected with intensity  $I_R$  and transmitted with intensity  $I_T$ . Permeability of each medium is the same. (Reflection coefficient  $R = \frac{I_R}{I_i}$  and Transmission coefficient  $T = \frac{I_T}{I_i}$ ).

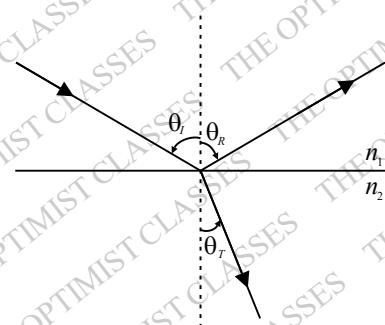

Choose the correct statement(s).

- (a)  $T = 1$  if  $\theta_i = 60^\circ$  and polarization of incident

light is perpendicular to the plane of incidence

(b)  $R=0$  if  $\theta_i = 60^\circ$  and polarization of incident light is perpendicular to the plane of incidence

(c)  $R=0$  if  $\theta_i = 0^\circ$  and polarization of incident light is parallel to the plane of incidence

(d)  $T=1$  if  $\theta_i = 60^\circ$  and polarization of incident light is parallel to the plane of incidence

33. The transition line, as shown in the figure, arises between  ${}^2D_{3/2}$  and  ${}^2P_{1/2}$  states without any external magnetic field. The number of lines that will appear in the presence of a weak magnetic field (in integer) is \_\_\_\_\_.



34. Consider a single one-dimensional harmonic oscillator of angular frequency  $\omega$ , in equilibrium at temperature  $T = (k_B \beta)^{-1}$ . The states of the harmonic oscillator are all non-degenerate having energy  $E_n = \left(n + \frac{1}{2}\right) \hbar \omega$  with equal probability, where  $n$  is the quantum number. The Helmholtz free energy of the oscillator is

(a)  $\frac{\hbar \omega}{2} + \beta^{-1} \ln [1 - \exp(-\beta \hbar \omega)]$

(b)  $\frac{\hbar \omega}{2} + \beta^{-1} \ln [1 + \exp(-\beta \hbar \omega)]$

(c)  $\frac{\hbar \omega}{2} + \beta^{-1} \ln [1 - \exp(\beta \hbar \omega)]$

(d)  $\beta^{-1} \ln [1 - \exp(-\beta \hbar \omega)]$

35. As shown in the figure, two metal-semiconductor junctions are formed between an  $n$ -type semiconductor  $S$  and metal  $M$ . The work functions of  $S$  and  $M$  are  $\phi_S$  and  $\phi_M$ , respectively with  $\phi_M > \phi_S$ .

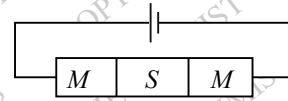

The  $I$ - $V$  characteristics (on linear scale) of the junctions is best represented by

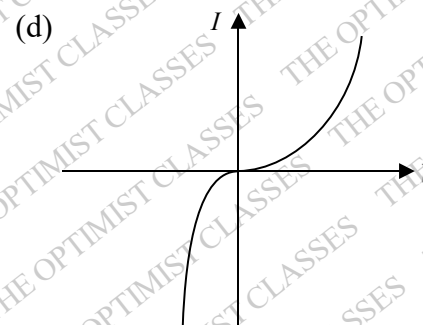
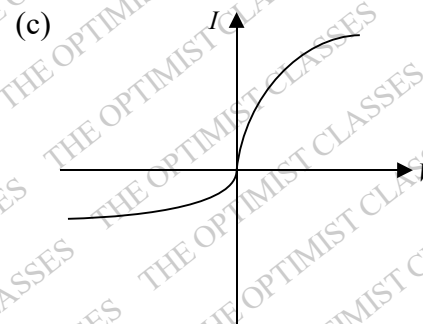
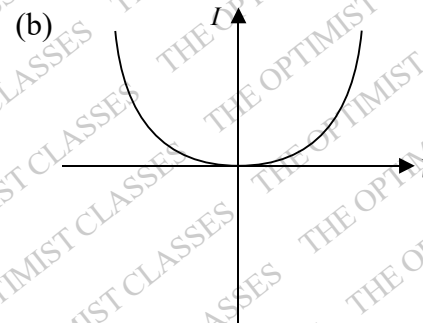
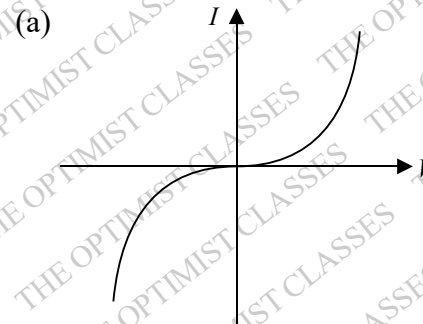

36. Two observers  $O$  and  $O'$  observe two events  $P$  and  $Q$ . The observers have a constant relative speed of  $0.5c$ . In the units, where the speed of

light,  $c$ , is taken as unity, the observer  $O$  obtained the following coordinates:

Event  $P$ :  $x = 5, y = 3, z = 5, t = 3$

Event  $Q$ :  $x = 5, y = 1, z = 3, t = 5$

The length of the space-time interval between these two events, as measured by  $O'$ , is  $L$ . The

value of  $|L|$  (in integer is \_\_\_\_\_).

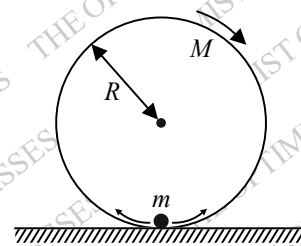

37.  $P$  and  $Q$  are two Hermitian matrices and there exists a matrix  $R$ , which diagonalizes both of them, such that  $RPR^{-1} = S_1$  and  $RQR^{-1} = S_2$ , where  $S_1$  and  $S_2$  are diagonal matrices. The correct statement(s) is/are

- (a) The matrix  $QP$  can have complex eigenvalues
- (b) The matrices  $P$  and  $Q$  commute
- (c) All the elements of both matrices  $S_1$  and  $S_2$  are real
- (d) The matrix  $PQ$  can have complex eigenvalues

38. A linear charged particle accelerator is driven by an alternating voltage source operating at  $10\text{MHz}$ . Assume that it is used to accelerate electrons. After a few drift-tubes, the electrons attain a velocity  $2.9 \times 10^8\text{m/s}$ . The minimum length of each drift-tube, in  $m$ , to accelerate the electrons further (rounded off to one decimal place) is \_\_\_\_\_.

39. The Coulomb energy component in the binding energy of a nucleus is  $18.432\text{MeV}$ . If the radius of the uniform and spherical charge distribution in the nucleus is  $3\text{fm}$ , the corresponding atomic number (rounded off to the nearest integer) is \_\_\_\_\_.

$$\left[ \text{Given: } \frac{e^2}{4\pi\epsilon_0} = 1.44\text{MeV fm} \right]$$

40. A hoop of mass  $M$  and radius  $R$  rolls without slipping along a straight line on a horizontal surface as shown in the figure. A point mass  $m$  slides without friction along the inner surface of the hoop, performing small oscillations about the mean position. The number of degrees of freedom of the system (in integer) is \_\_\_\_\_.

41. The time derivative of a differentiable function  $g(q_i, t)$  is added to a Lagrangian  $L(q_i, \dot{q}_i, t)$  such that

$$L' = L(q_i, \dot{q}_i, t) + \frac{d}{dt} g(q_i, t)$$

where  $q_i, \dot{q}_i, t$  are the generalized coordinates, generalized velocities and time, respectively. Let  $p_i$  be the generalized momentum and  $H$  the Hamiltonian associated with  $L(q_i, \dot{q}_i, t)$ . If  $p_i$  and  $H'$  are those associated with  $L'$ , then the correct option(s) is/are:

- (a) Both  $L$  and  $L'$  satisfy the Euler-Lagrange's equations of motion
- (b) If  $p_i$  is conserved, then  $p_i$  is necessarily conserved

$$(c) p'_i = p_i + \frac{\partial}{\partial q_i} g(q_i, t)$$

$$(d) H' = H + \frac{d}{dt} g(q_i, t)$$

42. Among the term symbols  $^4S_1, ^2D_{7/2}, ^3S_1$  and  $^2D_{5/2}$

Choose the option(s) possible in the LS coupling notation.

- (a)  $^2D_{7/2}$                       (b)  $^4S_1$
- (c)  $^3S_1$                          (d)  $^2D_{5/2}$

43. Consider a particle in a one-dimensional infinite potential well with its walls at  $x = 0$  and  $x = L$ . The system is perturbed as shown in the figure.

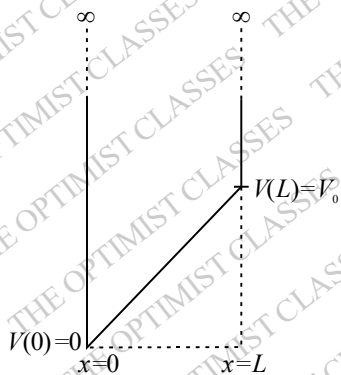

The first order correction to the energy eigenvalue is

- (a)  $\frac{V_0}{4}$  (b)  $\frac{V_0}{2}$   
 (c)  $\frac{V_0}{5}$  (d)  $\frac{V_0}{3}$

44. An electromagnetic wave having field

$\vec{E} = 8 \cos(kz - \omega t) \hat{y} Vcm^{-1}$  is incident at  $90^\circ$  (normal incidence) on a square slab from vacuum (with refractive index  $n_0 = 1.0$ ) as shown in the figure. The slab is composed of two different material with refractive indices  $n_1$  and  $n_2$ . Assume that the permeability of each medium is the same. After passing through the slab for the first time, the electric field amplitude, in  $Vcm^{-1}$ , of the electromagnetic wave, which emerges from the slab in region 2, is closest to

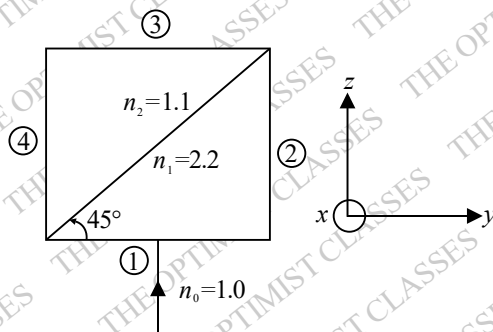

- (a)  $\frac{11}{3.2}$  (b)  $\frac{11}{25.6}$   
 (c)  $\frac{11}{13.8}$  (d)  $\frac{11}{1.6}$

45. For a two-nucleon system in spin singlet state, the

spin is represented through the Pauli matrices  $\sigma_1, \sigma_2$  for particles 1 and 2, respectively. The value of  $(\sigma_1 \cdot \sigma_2)$  (in integer) is \_\_\_\_\_.

46. In an experiment, it is seen that an electric-dipole ( $E1$ ) transition can connect an initial nuclear state of spin-parity  $J_i^\pi = 2^+$  to final state  $J_f^\pi$ . All possible values of  $J_f^\pi$  are

- (a)  $1^+, 2^+, 3^+$  (b)  $1^-, 2^-$   
 (c)  $1^-, 2^-, 3^-$  (d)  $1^+, 2^+$

47. Three non-interacting bosonic particles of mass  $m$  each, are in a one-dimensional infinite potential well of width  $a$ . The energy of the third excited state of the system is  $x \times \frac{\hbar^2 \pi^2}{ma^2}$ . The value of  $x$

(in integer) is \_\_\_\_\_.

48. The spacing between two consecutive S-branch lines of the rotational Raman spectra of hydrogen gas is  $243.2 cm^{-1}$ . After excitation with a laser of a wavelength  $514.5 nm$ , the stoke's line appeared at  $17611.4 cm^{-1}$  for a particular energy level. The wave number (rounded off to the nearest integer), in  $cm^{-1}$ , at which stoke's line will appear for the next higher energy level is \_\_\_\_\_.

49. A contour integral is defined as:

$$I_n = \oint_C \frac{dz}{(z-n)^2 + \pi^2}$$

Where  $n$  is a positive integer  $C$  is the closed contour, as shown in the figure, consisting of the line from  $-100$  to  $100$  and the semicircle traversed in the counter-clockwise sense.

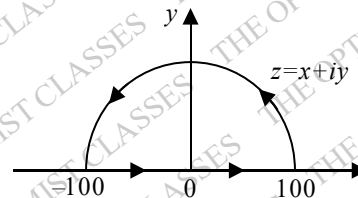

The value of  $\sum_{n=1}^5 I_n$  (in integer) is \_\_\_\_\_.

50. Consider two concentric conducting spherical shells as shown in the figure. The inner shell has a radius ' $a$ ' and carries a charge  $+Q$ . The outer shell has a radius ' $b$ ' and carries a charge  $-Q$ . The empty

space between them is half-filled by a hemispherical shell of a dielectric having permittivity  $\epsilon_1$ . The remaining space between the shells is filled with air having the permittivity  $\epsilon_0$ .

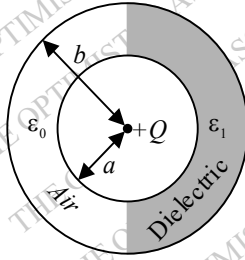

The electric field at a radial distance  $r$  from the center and between the shells ( $a < r < b$ ) is

(a)  $\frac{q}{4\pi\epsilon_0 r^2}$  on the air side and  $\frac{q}{4\pi\epsilon_1 r^2}$  on the dielectric side

(b)  $\frac{Q}{2\pi(\epsilon_0 + \epsilon_1)r^2}$  every where.

(c)  $\frac{Q}{2\pi\epsilon_0 r^2}$  on the air side and  $\frac{Q}{2\pi\epsilon_1 r^2}$  on the dielectric side.

(d)  $\frac{Q}{4\pi(\epsilon_0 + \epsilon_1)r^2}$  every where

51. A function  $f(t)$  is defined only for  $t \geq 0$ . The Laplace transform of  $f(t)$  is

$$L(f; s) = \int_0^{\infty} e^{-st} f(t) dt$$

whereas the fourier transform of  $f(t)$  is

$$\tilde{f}(\omega) = \int_0^{\infty} f(t) e^{-i\omega t} dt$$

The correct statement (s) is/are:

- (a)  $L(f; s)$  and  $\tilde{f}(\omega)$  can be made connected.  
 (b) The variable  $s$  is always real.  
 (c) The variable  $s$  can be complex.  
 (d)  $L(f; s)$  and  $\tilde{f}(\omega)$  can never be made connected.

52. The spin  $\vec{S}$  and orbital angular momentum  $\vec{L}$  of an atom precess about  $\vec{J}$ , the total angular momentum.  $\vec{J}$  precesses about an axis fixed by a magnetic field  $\vec{B}_1 = 2B_0\hat{z}$ , where  $B_0$  is a constant. Now the magnetic field is changed to  $\vec{B}_2 = B_0(\hat{x} + \sqrt{2}\hat{y} + \hat{z})$ . Given the orbital angular momentum quantum number  $l=2$  and spin quan-

tum number  $s = \frac{1}{2}$ ,  $\theta$  is the angle between  $\vec{B}_1$  and  $\vec{J}$  for the largest possible values of total angular quantum number  $j$  and its  $z$ -component  $j_z$ . The value of  $\theta$  (in degree, rounded off to the nearest integer) is \_\_\_\_\_

53. The donor concentration in a sample of  $n$ -type silicon is increased by a factor of 100. Assuming the sample to be non-degenerate, shift in the fermilevel (in  $meV$ ) at 300K (rounded off to the nearest integer) is \_\_\_\_\_.

[Given  $k_B T = 25 meV$  at 300K]

54. The Gell-Mann-Okuba mass formula defines the mass of baryons as  $M = M_0 + aY + b[I(I+1)$

$-\frac{1}{4}Y^2]$ , where  $M_0$ ,  $a$  and  $b$  are constants.  $I$  represents the isospin and  $y$  represents the hypercharge. If the mass of  $\Sigma$  hyperons is same as that of  $\Lambda$  hyperons, then the correct option (s) is (are)

- (a)  $M \propto Y$   
 (b)  $M \propto I(I+1)$

(c)  $M$  does not depend on  $I$

(d)  $M$  does not depend on  $Y$

55. Consider a spherical galaxy of total mass  $M$  and radius  $R$ , having a uniform matter distribution. In this idealized situation, the orbital speed  $v$  of a star of mass  $m$  ( $m \ll M$ ) as a function of the distance  $r$  from the galactic centre is best described by ( $G$  is the universal gravitational constant)

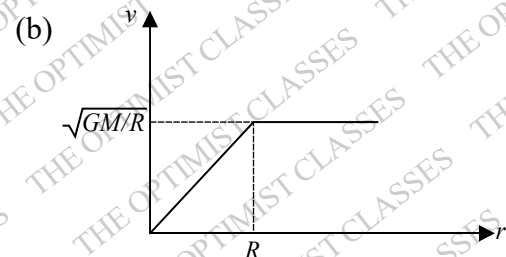
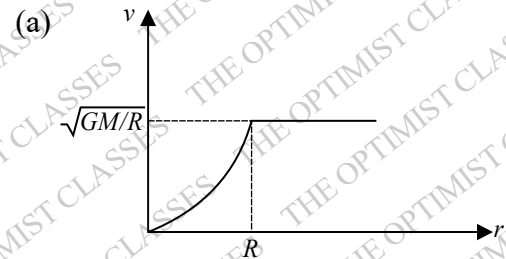

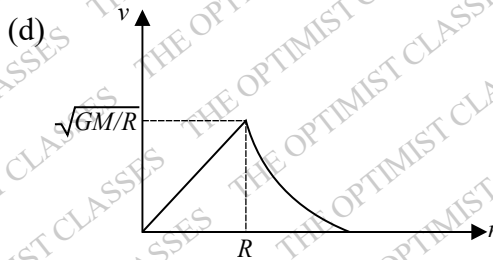
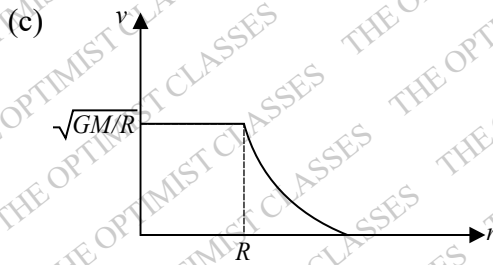

### ANSWER KEY

- |    |     |     |     |
|----|-----|-----|-----|
| 1. | (c) | 2.  | (b) |
| 3. | (b) | 4.  | (d) |
| 5. | (c) | 6.  | (a) |
| 7. | (d) | 8.  | (a) |
| 9. | (c) | 10. | (b) |

### SECTION - PHYSICS

- |     |                |     |                  |
|-----|----------------|-----|------------------|
| 1.  | (d)            | 2.  | (b, c)           |
| 3.  | (a)            | 4.  | (d)              |
| 5.  | (c)            | 6.  | (5000)           |
| 7.  | (c)            | 8.  | (a)              |
| 9.  | (b, c)         | 10. | (c)              |
| 11. | (2)            | 12. | (-1)             |
| 13. | (5.40 to 5.50) | 14. | (d)              |
| 15. | (d)            | 16. | (4)              |
| 17. | (0.24 to 0.26) | 18. | (c)              |
| 19. | (c)            | 20. | (3 to 5)         |
| 21. | (a, b)         | 22. | (a)              |
| 23. | (a)            | 24. | (b)              |
| 25. | (a, b, c)      | 26. | (a)              |
| 27. | (b, c)         | 28. | (b)              |
| 29. | (c, d)         | 30. | (b)              |
| 31. | (a)            | 32. | (d)              |
| 33. | (6)            | 34. | (a)              |
| 35. | (a)            | 36. | (2)              |
| 37. | (b, c)         | 38. | (14.0 to 15.0)   |
| 39. | (8 to 9)       | 40. | (2)              |
| 41. | (a, c)         | 42. | (c, d)           |
| 43. | (b)            | 44. | (d)              |
| 45. | (-3)           | 46. | (c)              |
| 47. | (5 to 6)       | 48. | (17367 to 17371) |
| 49. | (5)            | 50. | (b)              |
| 51. | (a, c)         | 52. | (27 to 93)       |
| 53. | (115 to 116)   | 54. | (a, c)           |
| 55. | (d)            |     |                  |