

THE OPTIMIST CLASSES IIT-JAM TOPPERS



MANOJ KUMAR SINGH



ABHAY



PAWAN



SATYAM



SOUMIL GIRISH SAHU



BHOOMIJA



AKSHIT AGGARWAL



SHIKHAR CHAMOLI



RAVI SINGH ADHIKARI



GAURAV JHA



SWAPNIL JOSHI



LOKESH BHATT



GOPESH VISHVAKARMA



VAIBHAV



SHASWAT CHAMOLI

CSIR-NET-JRF RESULTS 2022



ANNU
DL01000308

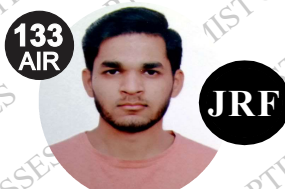

ALANKAR
UP15000162



SAHIL RANA
HR09000108



JAYESTHI
RJ11000161



DASRATH
RJ06000682



VIVEK
UK01000439



UZAIR AHMED
UP02000246



SURYA PRATAP SINGH
RJ06000232



HIMANSHU
UP10000095



CHANDAN
RJ09000159



SAIKHOM JOHNSON
MN01000196



AJAY SAINI
RJ06001744



VIKAS YADAV
RJ06001102



JYOTSNA KOHLI
UK02000262



SHYAM SUNDAR
RJ06000615

THE OPTIMIST CLASSES

AN INSTITUTE FOR NET-JRF/GATE/IIT-JAM/JEST/TIFR/M.Sc ENTRANCE EXAMS

CONTACT: 9871044043

CSIR-UGC-NET/JRF-DEC.-2011 PREVIOUS YEAR QUESTION PHYSICAL SCIENCES

Part - B

21. Consider three polarizers P_1, P_2 and P_3 placed along an axis as shown in the figure.

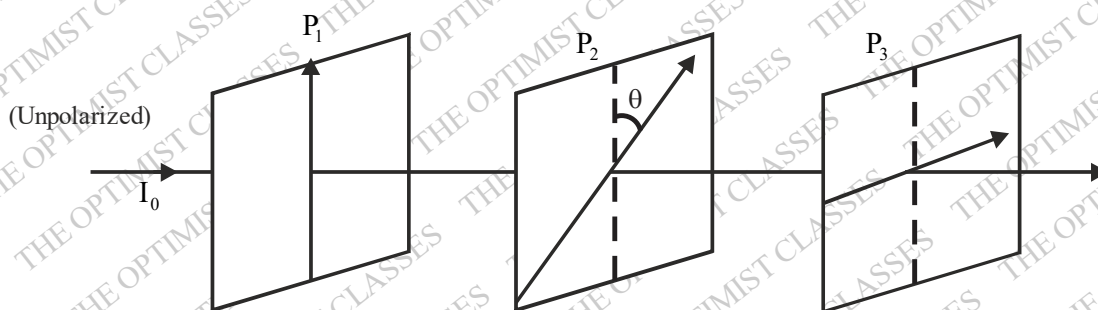

The pass axis of P_1 and P_3 are at right angles to each other while the pass axis of P_2 makes an angle θ with that of P_1 . A beam of unpolarized light of intensity I_0 is incident on P_1 as shown. The intensity of light emerging from P_3 is

- (a) 0 (b) $\frac{I_0}{2}$ (c) $\frac{I_0}{8} \sin^2 2\theta$ (d) $\frac{I_0}{4} \sin^2 2\theta$
22. A double pendulum consists of two point masses m attached by massless strings of length l as shown in the figure :

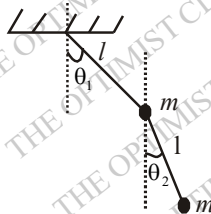

The kinetic energy of the pendulum is :

- (a) $\frac{1}{2} ml^2 [\dot{\theta}_1^2 + \dot{\theta}_2^2]$ (b) $\frac{1}{2} ml^2 [2\dot{\theta}_1^2 + \dot{\theta}_2^2 + 2\dot{\theta}_1\dot{\theta}_2 \cos(\theta_1 - \theta_2)]$
- (c) $\frac{1}{2} ml^2 [\dot{\theta}_1^2 + 2\dot{\theta}_2^2 + 2\dot{\theta}_1\dot{\theta}_2 \cos(\theta_1 - \theta_2)]$ (d) $\frac{1}{2} ml^2 [2\dot{\theta}_1^2 + \dot{\theta}_2^2 + 2\dot{\theta}_1\dot{\theta}_2 \cos(\theta_1 + \theta_2)]$

23. In the operational amplifier circuit below, the voltage at point A is

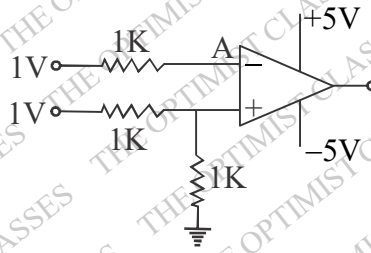

- (a) 1.0 V (b) 0.5 V (c) 0 V (d) - 5.0 V
24. A point particle of mass m carrying an electric charge q is attached to a spring of stiffness constant k . A constant electric field E along the direction of the spring is switched on for a time interval T (where $T \ll \sqrt{m/k}$). Neglecting radiation loss, the amplitude of oscillation after the field is switched off is:
- (a) qE/k (b) qET^2/m (c) $qE\sqrt{m}/Tk^{3/2}$ (d) qET/\sqrt{mk}
25. A constant force F is applied to a relativistic particle of rest mass m . If the particle starts from rest at $t = 0$, its speed after time t is
- (a) Ft/m (b) $c \tanh\left(\frac{Ft}{mc}\right)$ (c) $c \left(1 - e^{-Ft/mc}\right)$ (d) $\frac{Fct}{\sqrt{F^2t^2 + m^2c^2}}$
26. The potential of diatomic molecule as a function of the distance r between the atoms is given by $V(r) = -\frac{a}{r^6} + \frac{b}{r^{12}}$. The value of the potential at equilibrium separation between the atoms is:
- (a) $-4a^2/b$ (b) $-2a^2/b$ (c) $-a^2/2b$ (d) $-a^2/4b$
27. Four equal point charges are kept fixed at the four vertices of a square. How many neutral points (i.e., points where the electric field vanishes) will be found inside the square?
- (a) 3 (b) 4 (c) 5 (d) 7
28. A static charge distribution gives rise to an electric field of the form $\vec{E} = \alpha \left(1 - e^{-r/R}\right) \frac{\hat{r}}{r^2}$, where α and R are positive constants. The charge contained within a sphere of radius R , centred at the origin is:
- (a) $\pi\alpha\epsilon_0 = \frac{e}{R^2}$ (b) $\pi\alpha\epsilon_0 = \frac{e^2}{R^2}$ (c) $4\pi\alpha\epsilon_0 = \frac{R}{e}$ (d) $\pi\alpha\epsilon_0 = \frac{R^2}{e}$
29. A counter consists of four flip-flops connected as shown in the figure.

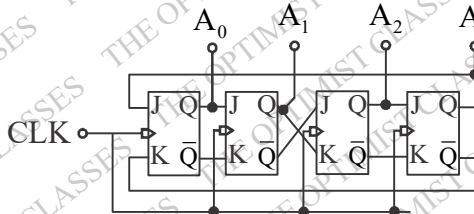

If the counter is initialized as $A_0 A_1 A_2 A_3 = 0110$, the state after the next clock pulse is

- (a) 1000 (b) 0001 (c) 0011 (d) 1100
30. In a Young's double slit interference experiment, the slits are at a distance $2L$ from each other and the screen is at a distance D from the slits. If a glass slab of refractive index μ and thickness d is placed in the path of

one of the beams, the minimum value of d for the central fringe to be dark is

- (a) $\frac{\lambda D}{(\mu-1)\sqrt{D^2+L^2}}$ (b) $\frac{\lambda D}{(\mu-1)L}$ (c) $\frac{\lambda}{(\mu-1)}$ (d) $\frac{\lambda}{2(\mu-1)}$

31. The pins 0,1,2 and 3 of part A of a microcontroller are connected with resistors to drive an LED at various intensities as shown in the figure.

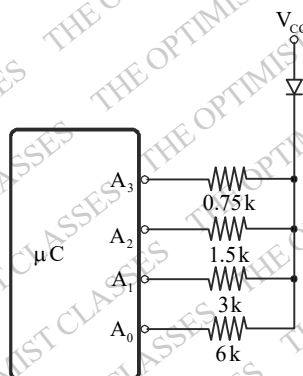

For $V_{cc} = 4.2\text{ V}$ and a voltage drop of 1.2 V across the LED, the range (maximum current) and resolution (step size) of the drive current are, respectively,

- (a) 4.0 mA and 1.0 mA (b) 15.0 mA and 1.0 mA
 (c) 7.5 mA and 0.5 mA (d) 4.0 mA and 0.5 mA

32. An unbiased dice is thrown three times successively. The probability that the numbers of dots on the uppermost surface add up to 16 is

- (a) $\frac{1}{16}$ (b) $\frac{1}{36}$ (c) $\frac{1}{108}$ (d) $\frac{1}{216}$

33. The generating function $F(x, t) = \sum_{n=0}^{\infty} P_n(x) t^n$ for the Legendre polynomials is $P_n(x)$ is

$F(x, t) = (1 - 2xt + t^2)^{-1/2}$. The value of $P_3(-1)$ is:

- (a) $5/2$ (b) $3/2$ (c) $+1$ (d) -1

34. Given that the ground state energy of the hydrogen atom is -13.6 eV , the ground state energy of positronium (which is a bound state of an electron and a positron) is

- (a) $+6.8\text{ eV}$ (b) -6.8 eV (c) -13.6 eV (d) -27.2 eV

35. Two particles of identical mass move in circular orbits under a central potential $V(r) = \frac{1}{2}kr^2$. Let

ℓ_1 and ℓ_2 be the angular momenta and r_1, r_2 be the radii of the orbits respectively. If $\ell_1/\ell_2 = 2$, the value of r_1/r_2 is:

- (a) $\sqrt{2}$ (b) $1/\sqrt{2}$ (c) 2 (d) $1/2$

36. The equation of the plane that is tangent to the surface $xyz=8$ at the point $(1,2,4)$ is

- (a) $x+2y+4z=12$ (b) $4x+2y+z=12$
 (c) $x+4y+2z=0$ (d) $x+y+z=7$

37. The energy of the first excited quantum state of a particle in the two-dimensional potential

$V(x, y) = \frac{1}{2} m\omega^2 (x^2 + 4y^2)$ is:

- (a) $2\hbar\omega$ (b) $3\hbar\omega$ (c) $\frac{3}{2}\hbar\omega$ (d) $\frac{5}{2}\hbar\omega$

38. The internal energy E of a system is given by $E = \frac{bS^3}{VN}$, where b is a constant and other symbols have their usual meaning. The temperature of this system is equal to

- (a) $\frac{bS^2}{VN}$ (b) $\frac{3bS^2}{VN}$ (c) $\frac{bS^3}{V^3N}$ (d) $\left(\frac{S}{N}\right)^2$

39. Consider a particle in a one dimensional potential that satisfies $V(x) = V(-x)$. Let $|\psi_0\rangle$ and $|\psi_1\rangle$ denote the ground and the first excited states, respectively, and let $|\psi\rangle = \alpha_0|\psi_0\rangle + \alpha_1|\psi_1\rangle$ be a normalized state with α_0 and α_1 being real constants. The expectations value $\langle x \rangle$ of the position operator x in the state $|\psi\rangle$ is given by

- (a) $\alpha_0^2 \langle \psi_0 | x | \psi_0 \rangle + \alpha_1^2 \langle \psi_1 | x | \psi_1 \rangle$ (b) $\alpha_0 \alpha_1 [\langle \psi_0 | x | \psi_1 \rangle + \langle \psi_1 | x | \psi_0 \rangle]$
 (c) $\alpha_0^2 + \alpha_1^2$ (d) $2\alpha_0\alpha_1$

40. A 3×3 matrix M has $Tr[M] = 6$, $Tr[M^2] = 26$ and $Tr[M^3] = 90$. Which of the following can be a possible set of eigenvalues of M ?

- (a) $\{1, 1, 4\}$ (b) $\{-1, 0, 7\}$ (c) $\{-1, 3, 4\}$ (d) $\{2, 2, 2\}$

41. The perturbation $H' = bx^4$, where b is a constant, is added to the one dimensional harmonic oscillator potential

$V(x) = \frac{1}{2} m\omega^2 x^2$. Which of the following denotes the correction to the ground state energy to first order in b ?

[Hint : The normalized ground state wave function of the one dimensional harmonic oscillator potential is

$\psi_0 = \left(\frac{m\omega}{h\pi}\right)^{1/4} e^{-\frac{m\omega x^2}{2\hbar}}$. You may use the following integral $\int_{-\infty}^{\infty} x^{2n} e^{-ax^2} dx = a^{-n-\frac{1}{2}} \Gamma\left(n + \frac{1}{2}\right)$

- (a) $\frac{3b\hbar^2}{4m^2\omega^2}$ (b) $\frac{3b\hbar^2}{2m^2\omega^2}$ (c) $\frac{3b\hbar^2}{2\pi m^2\omega^2}$ (d) $\frac{15b\hbar^2}{4m^2\omega^2}$

42. A battery powers two circuits C_1 and C_2 as shown in the figure

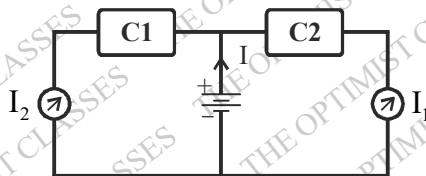

The total current I drawn from the battery is estimated by measuring the currents I_1 and I_2 through the individual circuits. If I_1 and I_2 are both 200mA and if the errors in their measurement are 3 mA and 4 mA respectively, the error in the estimate of I is:

- (a) 7.0 mA (b) 7.5 mA (c) 5.0 mA (d) 10.5 mA

43. Consider a Maxwellian distribution of the velocity of the molecules of an ideal gas. Let V_{mp} and V_{rms} denote the most probable velocity and the root mean square velocity, respectively. The magnitude of the ratio V_{mp} / V_{rms} is:
- (a) 1 (b) $2/3$ (c) $\sqrt{2/3}$ (d) $3/2$
44. If the number density of a free electron gas in three dimensions is increased eight times, its Fermi temperature will
- (a) increase by a factor of 4 (b) decrease by a factor of 4
(c) increase by a factor of 8 (d) decrease by a factor of 8
45. A system of N non-interacting spin $-\frac{1}{2}$ particles is placed in an external magnetic field H . The behaviour of the entropy of the system as a function of energy is given by

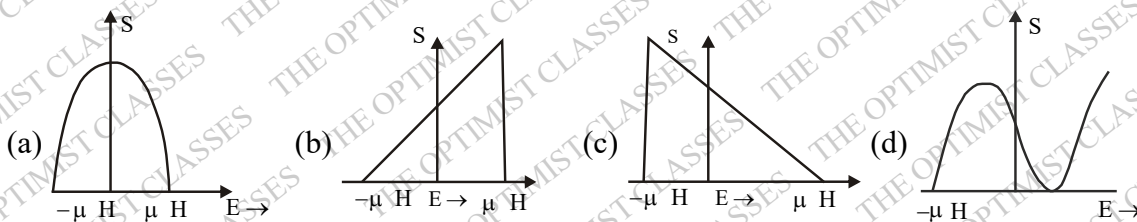

Part - C

46. A particle of mass 'm' moves inside a bowl. If the surface of the bowl is given by the equation $z = \frac{1}{2}a(x^2 + y^2)$, where a is a constant, the Lagrangian of the particle is:
- (a) $\frac{1}{2}m(\dot{r}^2 + r^2\dot{\phi}^2 - gar^2)$ (b) $\frac{1}{2}m[(1 + a^2r^2)\dot{r}^2 + r^2\dot{\phi}^2]$
(c) $\frac{1}{2}m(\dot{r}^2 + r^2\dot{\theta}^2 + r^2\sin^2\theta\dot{\phi}^2 - gar^2)$ (d) $\frac{1}{2}m[(1 + a^2r^2)\dot{r}^2 + r^2\dot{\phi}^2 - gar^2]$
47. An electron of energy 27 GeV collides with a proton of energy 820 GeV. The heaviest particle which can be produced in this collision has mass close to
- (a) 300 GeV (b) 821 GeV (c) 850 GeV (d) 1127 GeV
48. Let $x_1(t)$ and $x_2(t)$ be two linearly independent solutions of the differential equations $\frac{d^2x}{dt^2} + 2\frac{dx}{dt} + f(t)x = 0$, and let $w(t) = x_1(t)\frac{dx_2(t)}{dt} - x_2(t)\frac{dx_1(t)}{dt}$. If $w(0) = 1$ then $w(1)$ is given by
- (a) 1 (b) e^2 (c) $1/e$ (d) $1/e^2$
49. Assume that the free energy of a magnetic system has an expansion in the order parameter M of the form $F(M, T) = a(T - T_C)M^2 + bM^4 + cM^6$, with a, b and $c > 0$. As the temperature is lowered below T_C , the system undergoes a phase transition. The behaviour of the order parameter just below the transition, where $(T - T_C)$ is very small, is best described by
- (a) $M \propto (T_C - T)^{1/2}$ (b) $M \propto (T_C - T)^{1/2}$ (c) $M \propto (T_C - T)$ (d) $M \propto (T_C - T)^3$
50. A planet of mass m moves in the inverse square central force field of the Sun of mass M . If the semi-major and semi-minor axes of the orbit are a and b , respectively, the total energy of the planet is:

(a) $\frac{GMm}{a+b}$ (b) $-GMm\left(\frac{1}{a} + \frac{1}{b}\right)$ (c) $-GMm\left(\frac{1}{b} - \frac{1}{a}\right)$ (d) $-GMm\frac{(a-b)}{(a+b)^2}$

51. Let $|0\rangle$ and $|1\rangle$ denote the normalized eigenstates corresponding to the ground and first excited state of a one dimensional harmonic oscillator. The uncertainty Δp in the state $\frac{1}{\sqrt{2}}(|0\rangle + |1\rangle)$ is:

(a) $\Delta p = \sqrt{\hbar m \omega} / 2$ (b) $\Delta p = \sqrt{\hbar m \omega} / 2$ (c) $\Delta p = \sqrt{\hbar m \omega}$ (d) $\Delta p = \sqrt{2\hbar m \omega}$

52. A laser operating at 500nm is used to excite a molecule. If the Stokes line is observed at 770 cm^{-1} , the approximate positions of the Stokes and the anti-Stokes lines are

(a) 481.5 nm and 520 nm (b) 481.5 nm and 500 nm
(c) 500 nm and 520 nm (d) 500 nm and 600 nm

53. The graph of the function

$$f(x) = \begin{cases} 1 & \text{for } 2n \leq x \leq 2n+1 \\ 0 & \text{for } 2n+1 \leq x \leq 2n+2 \end{cases}$$

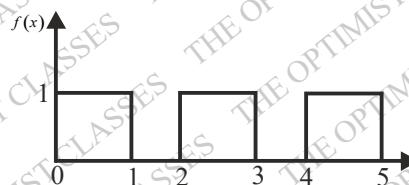

(where $n = 0, 1, 2, \dots$) is shown below:

Its Laplace transform $\tilde{f}(s)$ is

(a) $\frac{1+e^{-s}}{s}$ (b) $\frac{1-e^{-s}}{s}$ (c) $\frac{1}{s(1+e^{-s})}$ (d) $\frac{1}{s(1-e^{-s})}$

54. The energy levels of electrons of mass 'm' and charge 'e' confined in an area A in the xy-plane with a uniform magnetic field B applied in the z-direction are given by $E_n = \left(n + \frac{1}{2}\right) \frac{eB\hbar}{mc}$, $n = 0, 1, 2, \dots$

The degeneracy of each level is $\frac{eBA}{\hbar c}$. The lowest level is completely filled the other are empty. The

fermi energy $\frac{\hbar^2 N}{2\pi mA}$, where N is the total number of electrons, is:

(a) coincident with the $n = 0$ level (b) coincident with the $n = 1$ level
(c) midway between the $n = 0$ and the $n = 1$ levels.
(d) midway between the $n = 1$ and $n = 2$ levels.

55. An annulus of mass M made of a material of uniform density has inner and outer radii 'a' and 'b' respectively. Its principal moment of inertia along the axis of symmetry perpendicular to the plane of the annulus is:

(a) $\frac{1}{2}M\left(\frac{b^4 + a^4}{b^2 - a^2}\right)$ (b) $\frac{1}{2}M\pi(b^2 - a^2)$ (c) $\frac{1}{2}M(b^2 - a^2)$ (d) $\frac{1}{2}M(b^2 + a^2)$

56. The principal value of the real integral $I = \int_{-3}^{+3} \frac{dx}{x^2 + 3x + 2}$ is:

- (a) $\frac{3\pi}{2}$ (b) $\ln\left(\frac{2}{5}\right)$ (c) ∞ (d) 0

57. The minimum energy of an electron (the rest mass of which is 0.5 MeV) that can emit Cerenkov radiation while passing through water (of refractive index 1.5) is approximately

- (a) 1.0 MeV (b) 3.0 MeV (c) 0.6 MeV (d) 0.5 MeV

58. A heater and a thermocouple are used to measure and control temperature T of a sample at $T_0 = 250^\circ\text{C}$. A feedback circuit supplies power P to the heater according to the equation

$$P = P_0 + G(T_0 - T) - D \frac{dT}{dt}$$
 with appropriately tuned values of the coefficients G and D . In order to maintain temperature stability in the presence of an external heat perturbation which causes small but rapid fluctuations of temperature, it is necessary to

- (a) decrease D (b) increase D (c) decrease G (d) increase G

59. The trajectory on the $z p_z$ -plane (phase-space trajectory) of a ball bouncing perfectly elastically off a hard surface at $z = 0$ is given by approximately by (neglect friction):

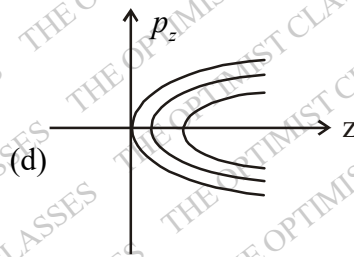
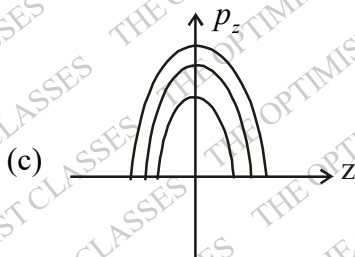
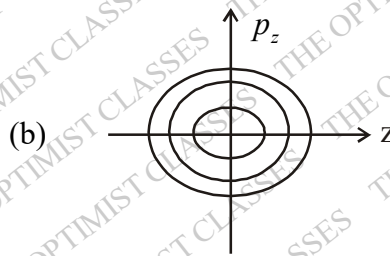
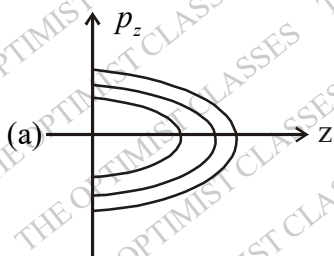

60. According to the shell model the spin and parity of the two nuclei $^{125}_{51}\text{Sb}$ and $^{89}_{38}\text{Sr}$ are, respectively.

- (a) $\left(\frac{5}{2}\right)^+$ and $\left(\frac{5}{2}\right)^+$ (b) $\left(\frac{5}{2}\right)^+$ and $\left(\frac{7}{2}\right)^+$ (c) $\left(\frac{7}{2}\right)^+$ and $\left(\frac{5}{2}\right)^+$ (d) $\left(\frac{7}{2}\right)^+$ and $\left(\frac{7}{2}\right)^+$

61. The wave function of a particle at time $t = 0$ is given by $|\psi(0)\rangle = \frac{1}{\sqrt{2}}(|u_1\rangle + |u_2\rangle)$, where $|u_1\rangle$ and $|u_2\rangle$ are the normalized eigenstates with eigenvalues E_1 and E_2 respectively, ($E_2 > E_1$). The shortest time after which $|\psi(t)\rangle$ will become orthogonal to $|\psi(0)\rangle$ is

- (a) $\frac{-\hbar\pi}{2(E_2 - E_1)}$ (b) $\frac{\hbar\pi}{E_2 - E_1}$ (c) $\frac{\sqrt{2}\hbar\pi}{E_2 - E_1}$ (d) $\frac{2\hbar\pi}{E_2 - E_1}$

62. A gas of N non-interacting particles is in thermal equilibrium at temperature T . Each particle can be in any of the possible non-degenerate states of energy 0 , 2ε and 4ε . The average energy per particle of the gas, when $\beta\varepsilon \ll 1$ is

- (a) 2ε (b) 3ε (c) $2\varepsilon/3$ (d) ε

63. The first few terms in the Taylor series expansion of the function $f(x) = \sin x$ around $x = \frac{\pi}{4}$ are

(a) $\frac{1}{\sqrt{2}} \left[1 + \left(x - \frac{\pi}{4}\right) + \frac{1}{2!} \left(x - \frac{\pi}{4}\right)^2 + \frac{1}{3!} \left(x - \frac{\pi}{4}\right)^3 \dots \right]$

(b) $\frac{1}{\sqrt{2}} \left[1 + \left(x - \frac{\pi}{4}\right) - \frac{1}{2!} \left(x - \frac{\pi}{4}\right)^2 - \frac{1}{3!} \left(x - \frac{\pi}{4}\right)^3 \dots \right]$

(c) $\left[\left(x - \frac{\pi}{4}\right) - \frac{1}{3!} \left(x - \frac{\pi}{4}\right)^3 \dots \right]$

(d) $\frac{1}{\sqrt{2}} \left[1 - x + \frac{x^2}{2!} - \frac{x^3}{3!} \dots \right]$

64. A one-dimensional chain consists of a set of N rods each of length a . When stretched by a load, each rod can align either parallel or perpendicular to the length of the chain. The energy of a rod is $-\varepsilon$ when aligned parallel to the length of the chain and is $+\varepsilon$ when perpendicular to it. When the chain is in thermal equilibrium at temperature T , its average length is:

- (a) $Na/2$ (b) Na (c) $Na / (1 + e^{-2\varepsilon/k_B T})$ (d) $Na / (1 + e^{2\varepsilon/k_B T})$

65. If the hyperfine interaction in an atom is given by $H = a \vec{S}_e \cdot \vec{S}_p$ where \vec{S}_e and \vec{S}_p denote the electron and proton spins, respectively, the splitting between the 3S_1 and 1S_0 state is

- (a) $a\hbar^2/\sqrt{2}$ (b) $a\hbar^2$ (c) $a\hbar^2/2$ (d) $2a\hbar^2$

66. Consider a solenoid of radius R with n turns per unit length, in which a time dependent current $I = I_0 \sin \omega t$ (where $\omega R/c \ll 1$) flows. The magnitude of the electric field at a perpendicular distance $r < R$ from the axis of symmetry of the solenoid, is:

- (a) 0 (b) $\frac{1}{2r} \omega \mu_0 n I_0 R^2 \cos \omega t$

- (c) $\frac{1}{2} \omega \mu_0 n I_0 r \sin \omega t$ (d) $\frac{1}{2} \omega \mu_0 n I_0 r \cos \omega t$

67. The difference in the Coulomb energy between the mirror nuclei $^{49}_{24}\text{Cr}$ and $^{49}_{25}\text{Mn}$ is 6.0 MeV. Assuming that the nuclei have a spherically symmetric charge distribution and that e^2 is approximately 1.0

MeV-fm, the radius of the $^{49}_{25}\text{Mn}$ nucleus is

- (a) 4.9×10^{-13} m (b) 4.9×10^{-15} m (c) 5.1×10^{-13} m (d) 5.1×10^{-15} m

68. The ratio of intensities of the D_1 and D_2 lines of sodium at high temperature

- (a) 1 : 1 (b) 2 : 3 (c) 1 : 3 (d) 1 : 2

69. A constant perturbation as shown in the figure below acts on a particle of mass m confined in a infinite potential well between 0 and L . The first-order correction to the ground state energy of the particle is

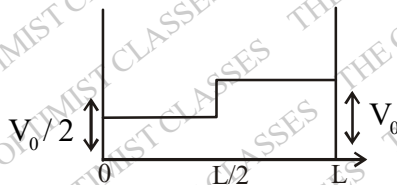

(a) $\frac{V_0}{2}$

(b) $\frac{3V_0}{4}$

(c) $\frac{V_0}{4}$

(d) $\frac{3V_0}{2}$

70. An atom of mass M can be excited to a state of mass $M + \Delta$ by photon capture. The frequency of a photon which can cause this transition is:

(a) $\Delta c^2 / 2h$

(b) $\Delta c^2 / h$

(c) $\Delta^2 c^2 / 2Mh$

(d) $\Delta(\Delta + 2M)c^2 / 2Mh$

71. The excitation of a three-dimensional solid are bosonic in nature with their frequency ω and wave number k are related by $\omega \propto k^2$ in the large wavenumber limit. If the chemical potential is zero, the behaviour of the specific heat of the system at low temperature is proportional to

(a) $T^{1/2}$

(b) T

(c) $T^{3/2}$

(d) T^3

72. Gas molecules of mass 'm' are confined in a cylinder of radius R and height L (with $R \gg L$) kept vertically in the Earth's gravitational field. The average energy of the gas at low temperatures (such that $mgL \gg k_B T$) is given by

(a) $Nk_B T / 2$

(b) $3Nk_B T / 2$

(c) $2Nk_B T$

(d) $5Nk_B T / 2$

73. The figure below shows a voltage regulator utilizing a Zener diode of breakdown voltage 5V and positive triangular wave input of amplitude 10V.

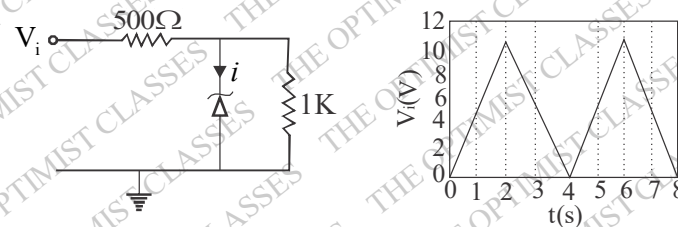

For $V_i > 5V$, the Zener regulates the output voltage by channeling the excess current through it itself. Which of the following wave forms shows the current 'i' passing through the Zener diode?

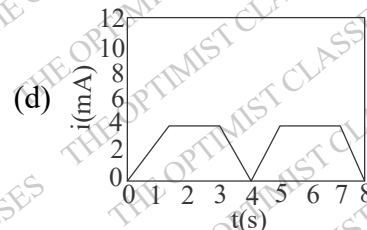
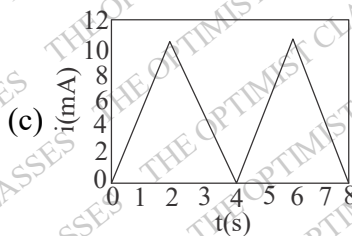
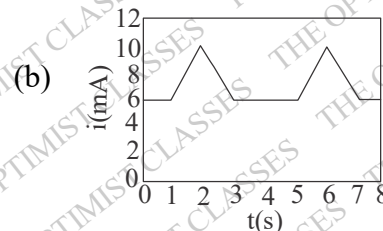
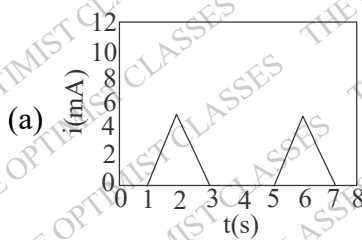

74. A constant electric current I in an infinitely long straight wire is suddenly switched on at $t=0$. vector potential at a perpendicular distance r from the wire is given by

$\vec{A} = \frac{\hat{k}\mu_0 I}{2\pi} \ln \left[\frac{1}{r} \left(ct + \sqrt{c^2 t^2 - r^2} \right) \right]$. The electric field at a distance $r (< ct)$ is:

- (a) 0
 (b) $\frac{\mu_0 I}{2\pi t} \frac{1}{\sqrt{2}} (\hat{i} - \hat{j})$
 (c) $\frac{c\mu_0 I}{2\pi\sqrt{c^2 t^2 - r^2}} \frac{1}{\sqrt{2}} (\hat{i} - \hat{j})$
 (d) $-\frac{c\mu_0 I}{2\pi\sqrt{c^2 t^2 - r^2}} \hat{k}$

75. Monochromatic light of wavelength 660 nm and intensity $100 \text{ mW} / \text{cm}^2$ falls on a solar cell of area 30 cm^2 . The conversion efficiency of the solar cell is 10%. If each converted photon results in an electron-hole pair, what is the maximum circuit current supplied by the solar cell?

(Take $h = 6.6 \times 10^{-34} \text{ J-s}$, $c = 3 \times 10^8 \text{ m/s}$ and $e = 1.6 \times 10^{-19} \text{ C}$)

- (a) 160 mA (b) 320 mA (c) 1600 mA (d) 3200 mA

ANSWER KEY

- | | | | | | | |
|---------|---------|---------|---------|---------|---------|---------|
| 21. (c) | 22. (b) | 23. (a) | 24. (d) | 25. (d) | 26. (c) | 27. (c) |
| 28. (*) | 29. (c) | 30. (d) | 31. (c) | 32. (b) | 33. (d) | 34. (b) |
| 35. (a) | 36. (b) | 37. (d) | 38. (b) | 39. (b) | 40. (c) | 41. (a) |
| 42. (c) | 43. (c) | 44. (a) | 45. (d) | 46. (c) | 47. (c) | 48. (d) |
| 49. (b) | 50. (a) | 51. (c) | 52. (a) | 53. (c) | 54. (b) | 55. (d) |
| 56. (b) | 57. (c) | 58. (a) | 59. (a) | 60. (c) | 61. (b) | 62. (a) |
| 63. (c) | 64. (c) | 65. (b) | 66. (d) | 67. (b) | 68. (d) | 69. (b) |
| 70. (d) | 71. (c) | 72. (d) | 73. (b) | 74. (d) | 75. (a) | |